

XTLINE[®]

PROFESSIONAL TOOLS

POWER TOOLS

valid from 10/2022



Born for outstanding projects.

ABOUT US

We are a family company XTline s.r.o. and for the past 20 years we have been producing and supplying hand tools, power and cordless tools to large number of specialized shops – small and medium size hardware stores run by friendly and professional personnel, as well as artisans and professional contractors of various fields. In order to find the best solution for each customer, you will never find us in large, anonymous hobby markets and retail shop centers.

HISTORY

The company was founded in 2001 and is based on a family tradition of a hardware store that dates back to 1992. Since then, however, many talented people have joined and due to hard work, the company has been officially registered on the European market since 2008. Our customers are actively looked after by trained and experienced sales representatives and carefully selected distributors with operations not only in the Czech Republic, but also Slovakia, Poland, Latvia, Hungary, Romania, Germany and other countries.

OUR OFFER

Our portfolio consists of a wide range of high-quality hand tools, workshop equipment and tools for processing wood, metal and other materials, battery and power tools for standard and special applications and many more products that find application in both normal and professional use. We are constantly developing and optimizing our products so that they can withstand the most stringent standards and make working with them a rewarding experience.

Our entire comprehensive and product-diverse Cordless program is fully compatible with one type of battery. High-quality Li-Ion cells in battery packs of various capacities ensure that even the most demanding customer will find the right combination of tools for their project. Every year, we bring a number of new items that you, our customers, have been frequently presented at fairs, road shows and other events. Your joy and valuable experience from successfully completed projects is the main motivation for us and the reason to never stop improving. Every day, we carry out our tasks consistently, professionally and at the highest quality possible. Our reward is YOU – satisfied customers, craftsmen and business owners who enjoy working with XTLINE tools and who identify with the slogan we follow:

XTLINE®
PROFESSIONAL TOOLS



Born for outstanding projects.

PICTOGRAMS

| | | | |
|---|----------------------|---|---------------------------------|
|  | hammer drilling |  | 1 battery |
|  | drilling |  | 2 batteries |
|  | screwing |  | battery type |
|  | chisel |  | charging time |
|  | demolition |  | box |
|  | SDSplus clamping |  | accessories |
|  | SDSmax clamping |  | plastics |
|  | HEX clamping |  | stone, bricks... |
|  | clamping 1/2" |  | wood |
|  | LED lighting |  | steel, iron... |
|  | speed control |  | aluminum and non-ferrous metals |
|  | two-way operation |  | plasterboard |
|  | 2 speeds |  | grass |
|  | laser |  | branches |
|  | USB power supply |  | maximum liquid temperature |
|  | power cord length |  | maximum throughput |
|  | hose length |  | maximum immersion depth |
|  | does not contain oil |  | maximum displacement |



Born for outstanding projects.



) CORDLESS SETS

4 - 5

) DRILLS
) ROTARY HAMMERS
) DEMOLITION HAMMERS
) SHEARS

48 - 57



) CORDLESS SCREWDRIVERS
) CORDLESS ROTARY HAMMERS
) CORDLESS DRILLS
) CORDLESS IMPACT WRENCHES

6 - 16



) ANGLE GRINDERS
) OSCILLATING SANDERS
) BELT SANDERS
) BENCH GRINDERS
) TOOL SHARPENERS
) ROUTERS

58 - 89



) CORDLESS ANGLE GRINDERS AND SANDERS

17 - 22



) SAWS
) PLANERS
) MITER SAWS

90 - 101



) CORDLESS PLANERS
) CORDLESS SAWS

23 - 29



) PIPE WELDERS
) WELDING INVERTERS
) HEAT GUNS

102 - 105



) CORDLESS COMPRESSORS
) CORDLESS LIGHTS

30 - 32



) AIR COMPRESSORS
) VACUUM CLEANERS

106 - 113



) CORDLESS CHAINSAWS
) CORDLESS SHEARS
) CORDLESS LAWN MOWERS
) CORDLESS GARDEN VACUUM CLEANERS
) CORDLESS GARDEN SPRAYERS

33 - 40



) HOISTS
) PADDLE MIXERS
) CONSTRUCTION MIXERS

114 - 117



) CHARGERS
) BATTERY PACKS
) CORDLESS SETS
) COMING SOON

41 - 45



) HOT GLUE GUNS
) SOLDERING GUNS
) HIGH PRESSURE WASHERS
) PUMPS

118 - 131

XTPOWER

ONE BATTERY FOR ALL



XTLINE[®] PROFESSIONAL TOOLS



ADVANTAGES OF THE SYSTEM XTPOWER

- › LED indication of battery capacity
- › battery temperature and voltage are monitored by a microprocessor
- › high-quality lithium cells guarantee a long battery life

- › the Li-Ion battery has minimal self-discharge loss
- › rubber surface design is resistant to impacts and guarantees a firm grip
- › 18 V battery system offers battery capacities of 2.0, 4.0, 5.0, and 6.0 Ah

Born for outstanding projects.



CORDLESS TOOL KIT 18 V, 10 PCS

+ BAG

The XTLINE Combo Kit includes Cordless Drill, Impact Driver, 115mm Angle Grinder, Random Orbit Sander, Reciprocating Saw, Circular Saw, 2 x 18 V, 2.0 Ah Battery, 1 x 18 V, 4.0 Ah Battery, and Battery Charger. All tools are equipped with an ergonomic, soft, anti-slip handle for safe operation. The XTPOWER battery system provides enough energy for a great number of XTLINE cordless power tools. A single battery can power all products within the Combo Kit.

Main features:

All tools are compatible with one battery type and come in a practical tool bag.

Product includes:

- XT102700: Cordless Drill 18 V
- XT102710: Cordless Impact Driver 18 V
- XT102720: Cordless Angle Grinder 115mm, 18 V
- XT102730: Cordless Reciprocating Saw 18 V
- XT102740: Cordless Random Orbit Sander 18 V
- XT102745: Cordless Circular Saw 165 mm, 18 V
- XT102782E: 2x Battery pack EVE Li-Ion 18 V, 2.0 Ah
- XT102784E: Battery pack EVE Li-Ion 18 V, 4.0 Ah
- XT102785: Battery Charger, Li-Ion 18 V, 2.4 A
- XT90060: Roller Tool Bag with Telescopic Handle, 670x300x310 mm



Technical specifications

| | |
|--------------|-----------------|
| Order Number | XT102600 |
| Voltage | 18 V |
| Weight | 14 kg |

CORDLESS TOOL KIT 18 V, BRUSHLESS, 6 PCS

+ BOX

The XTLINE Combo Kit includes Brushless Cordless Hammer Drill, Brushless Cordless Angle Grinder 125mm, 1 x 18 V, 2.0 Ah Battery, 1 x 18 V, 4.0 Ah Battery, and Battery Charger. All tools are equipped with an ergonomic, soft, anti-slip handle for safe operation. The XTPOWER battery system provides enough energy for a great number of XTLINE cordless power tools. A single battery can power all products within the Combo Kit.

Main features:

BRUSHLESS

All tools are compatible with one battery type and come in a practical box.

Product includes:

- XT102800: Cordless Drill 18 V, BRUSHLESS
- XT102835: Cordless Angle Grinder 125mm, 18 V, BRUSHLESS
- XT102782E: Battery pack EVE Li-Ion 18 V, 2.0 Ah
- XT102784E: Battery pack EVE Li-Ion 18 V, 4.0 Ah
- XT102790: Battery Charger, Li-Ion 18 V, 3.5 A
- P90603: Box plastic Qbrick PRO Toolbox 450x334x240mm



Technical specifications

| | |
|--------------|-----------------|
| Order Number | XT102630 |
| Voltage | 18 V |
| Weight | 7,1 kg |

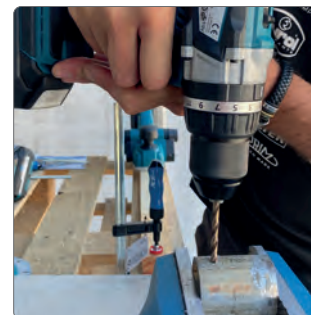



CORDLESS SCREWDRIVER 3.6 V

+ BOX

Small, compact Cordless Screwdriver designed to tighten and loosen screws, bolts, etc. Rotatable handle, direction of rotation switch, and torque regulation. The product includes a practical plastic case, accessories, charging adapter + USB adapter cable.

Main features:

- LED work light
- Left and right direction of rotation
- Torque regulation
- Great selection of accessories

Technical specifications

| | |
|----------------------------|--|
| Order Number | XT102106 |
| Voltage | 3.6 V |
| Speed | 200 rpm |
| Max. torque | 4 Nm |
| Torque adjustment | 10+1 |
| Battery capacity | 1.5 Ah |
| Battery charge time | 3 - 5 h |
| Clamping | 1/4" |
| Sound pressure level (LpA) | 61.7 dB |
| Sound power level (LwA) | 73 dB |
| Other features | Left/right direction, LED work light |
| Product includes | Driver bit kit, charging adapter, USB cable |
| Weight without battery | 0.5 kg |



CORDLESS ROTARY HAMMER 18 V, BRUSHLESS, SDS PLUS

WITHOUT BATTERY

The Cordless Rotary Hammer is designed for light drilling and cutting masonry and concrete, chiseling plasters, and tiling, drilling anchor and through holes, and core drilling. A mode switch adjustable at drilling, hammer drilling, lock, and chiseling position. LED work light. It is possible to purchase individual batteries and chargers.

Main features:

BRUSHLESS

- 4-action modes: drilling, hammer drilling, lock position, cutting
- SDS PLUS chuck
- LED work light
- Ergonomically shaped rubber handle



Technical specifications

| | |
|----------------------------|---|
| Order Number | XT102840 |
| Voltage | 18 V |
| Speed | 0-1,420 rpm |
| Number of BPM | 0-4,500 BPM |
| Impact energy | 2.2 J |
| Functions | drilling, hammer drilling, chiselling and lock-position |
| Clamping | SDS PLUS |
| Sound pressure level (LpA) | 87 dB |
| Sound power level (LwA) | 98 dB |
| Product includes | Handle, Depth stop |
| Weight without battery | 2.3 kg |





CORDLESS DRILL 10.8 V

+ 2 BATTERY PACKS 2.0 AH + BOX

A two-speed Cordless Screwdriver for screwing and drilling wood, metal, and plastics. Compact and light design. The Drill offers a quick-release chuck system with a possibility of screwing using a 1/4" bit holder.

Main features:

- LED work light
- Ergonomically shaped rubber handle
- Great selection of accessories

Technical specifications

| | |
|----------------------------|---|
| Order Number | XT102699 |
| Voltage | 10.8 V |
| Speed | 0-350 / 0-1,350 rpm |
| Max. torque | 25 Nm |
| Torque adjustment | 18+1 |
| Max drilling diameter | metal 6 mm, masonry 10 mm, wood 20 mm |
| Drill bit diameter | 0.8-10 mm |
| Battery capacity | 2.0 Ah |
| Battery charge time | 1 h |
| Speed control positions | 2 |
| Clamping | chuck / bit holder |
| Sound pressure level (LpA) | 70.7 dB |
| Sound power level (LwA) | 81.7 dB |
| Other features | Left/right direction, LED work light, electronic speed regulation |
| Product includes | 2x Battery pack 2.0 Ah, bit holder, driver bit set, drill bit set, box |
| Weight without battery | 0.9 kg |

Technical specifications

| | |
|---------------------|-----------------|
| Order Number | XT102698 |
| Voltage | 18 V |
| Battery charge time | 1 h |
| Weight | 0.2 kg |



EVE

CORDLESS DRILL 18 V WITHOUT BATTERY

The Cordless Drill allows comfortable operation due to an ergonomic, rubber handle. More effective operation is provided by a motor brake, dustproof planetary gearbox with metal gears, and quick-release chuck – easier to insert and remove bits using one hand only. The Battery and Battery Charger not included. It is possible to purchase individual batteries and chargers.

Main features:

LED work light
Magnetic bit holder
Quick-release chuck

Technical specifications

| | |
|----------------------------|---|
| Order Number | XT102700 |
| Voltage | 18 V |
| Speed | 0-400 / 0-1,400 rpm |
| Max. torque | 35 Nm |
| Torque adjustment | 25+1 |
| Max drilling diameter | metal 12 mm, masonry 15 mm, wood 25 mm |
| Drill bit diameter | 2-13 mm |
| Speed control positions | 2 |
| Clamping | keyless chuck |
| Sound pressure level (LpA) | 64.4 dB |
| Sound power level (LwA) | 75.4 dB |
| Other features | Left/right direction, LED work light, magnetic bit holder, electronic speed regulation |
| Weight without battery | 1.1 kg |





CORDLESS DRILL 18 V

+ 2 BATTERY PACKS 2.0 AH + BOX

The Cordless Drill is designed for drilling and screwing in areas without electricity supply. Comfortable operation due to an ergonomic, rubber handle. More effective operation is provided by a motor brake, dustproof planetary gearbox with metal gears, and quick-release chuck - easier to insert and remove bits using one hand only.

Main features:

- LED work light
- Magnetic bit holder
- Quick-release chuck
- Two-speed planetary gearbox with metal gears

Technical specifications

| | |
|----------------------------|--|
| Order Number | XT102770E |
| Voltage | 18 V |
| Speed | 0-400 / 0-1,400 rpm |
| Max. torque | 35 Nm |
| Torque adjustment | 25+1 |
| Max drilling diameter | metal 12 mm, masonry 15 mm, wood 25 mm |
| Drill bit diameter | 2-13 mm |
| Speed control positions | 2 |
| Clamping | keyless chuck |
| Sound pressure level (LpA) | 64.4 dB |
| Sound power level (LwA) | 75.4 dB |
| Product includes | 2x Battery pack 2.0 Ah, charger 2.4 A, bit holder, drill bit set, driver bit set, box |
| Weight without battery | 1.1 kg |

EVE



CORDLESS HAMMER DRILL 18 V, BRUSHLESS

WITHOUT BATTERY

The Cordless Drill is designed for drilling or screwing using a two-speed planetary gearbox with metal gears. It offers an ergonomic, rubber handle, one-piece quick-release chuck + LED work light. The Battery and Battery Charger not included. It is possible to purchase individual batteries and chargers.

Main features:

Metal quick-release chuck
LED work light

BRUSHLESS

Technical specifications

| | |
|----------------------------|--|
| Order Number | XT102800 |
| Voltage | 18 V |
| Speed | 0-500 / 0-2,000 rpm |
| Max. torque | 65 Nm |
| Torque adjustment | 21+3 |
| Number of BPM | 0-7,500 / 0-30,000 BPM |
| Max drilling diameter | metal 12 mm, masonry 15 mm, wood 25 mm |
| Drill bit diameter | 2-13 mm |
| Speed control positions | 2 |
| Clamping | keyless chuck |
| Sound pressure level (LpA) | 68.2 dB |
| Sound power level (LwA) | 75.3 dB |
| Other features | Left/right direction, LED work light, electronic speed regulation |
| Weight without battery | 1.2 kg |





CORDLESS HAMMER DRILL 18 V, BRUSHLESS

+ 2 BATTERY PACKS 2.0 AH EVE + BOX

The Cordless Drill is designed for drilling or screwing using a two-speed planetary gearbox with metal gears. It offers an ergonomic, rubber handle, one-piece quick-release chuck + LED work light. The Battery and Battery Charger included. It is possible to purchase individual batteries and chargers.

Main features:

BRUSHLESS

- Metal quick-release chuck
- LED work light

Technical specifications

| | |
|----------------------------|--|
| Order Number | XT102860E |
| Voltage | 18 V |
| Speed | 0-500 / 0-2,000 rpm |
| Max. torque | 65 Nm |
| Torque adjustment | 21+3 |
| Number of BPM | 0-7,500 / 0-30,000 BPM |
| Max drilling diameter | metal 12 mm, masonry 15 mm, wood 25 mm |
| Drill bit diameter | 2-13 mm |
| Speed control positions | 2 |
| Clamping | keyless chuck |
| Sound pressure level (LpA) | 68.2 dB |
| Sound power level (LwA) | 75.3 dB |
| Other features | Left/right direction, LED work light, electronic speed regulation |
| Product includes | 2x Battery pack 2.0 Ah EVE, charger 2.4 A, box |
| Weight without battery | 1.2 kg |

EVE



CORDLESS HAMMER DRILL 18 V, BRUSHLESS

+ 2 BATTERY PACKS 4.0 AH EVE + BOX

The Cordless Drill is designed for drilling or screwing using a two-speed planetary gearbox with metal gears. It offers an ergonomic, rubber handle, one-piece quick-release chuck + LED work light. The Battery and Battery Charger included. It is possible to purchase individual batteries and chargers.

Main features:

Metal quick-release chuck
LED work light

Technical specifications

| | |
|----------------------------|--|
| Order Number | XT102865E |
| Voltage | 18 V |
| Speed | 0-500 / 0-2,000 rpm |
| Max. torque | 65 Nm |
| Torque adjustment | 21+3 |
| Number of BPM | 0-7,500 / 0-30,000 BPM |
| Max drilling diameter | metal 12 mm, masonry 15 mm, wood 25 mm |
| Drill bit diameter | 2-13 mm |
| Speed control positions | 2 |
| Clamping | keyless chuck |
| Sound pressure level (LpA) | 68.2 dB |
| Sound power level (LwA) | 75.3 dB |
| Other features | Left/right direction, LED work light, electronic speed regulation |
| Product includes | 2x Battery pack 4.0 Ah EVE, charger 3.5 A, box |
| Weight without battery | 1.2 kg |

BRUSHLESS

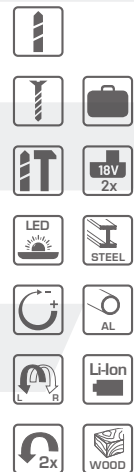

EVE

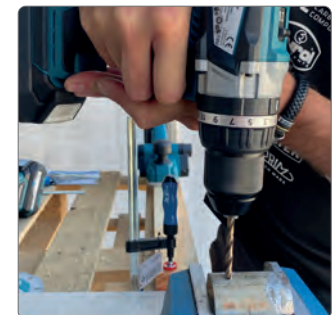
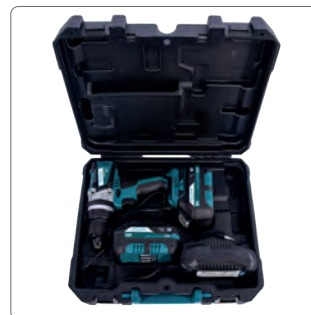



CORDLESS IMPACT DRIVER 18 V

WITHOUT BATTERY

The impact mechanism allows work with long screws and specific wood screws. Electronic speed regulation and motor brake. The Battery and Battery Charger not included. It is possible to purchase individual batteries and chargers.

Main features:

- LED work light
- Magnetic bit holder
- Ergonomically shaped rubber handle

Technical specifications

| | |
|----------------------------|---|
| Order Number | XT102710 |
| Voltage | 18 V |
| Speed | 0-2,800 rpm |
| Max. torque | 180 Nm |
| Number of BPM | 0-3,600 BPM |
| Clamping | 1/4" |
| Sound pressure level (LpA) | 99 dB |
| Sound power level (LwA) | 110 dB |
| Other features | Left/right direction, LED work light, magnetic bit holder, electronic speed regulation |
| Weight without battery | 1.2 kg |

CORDLESS IMPACT DRIVER 18 V

+ 2 BATTERY PACKS 2.0 AH + BOX

The impact mechanism allows work with long screws and specific wood screws. Electronic speed regulation and motor brake, left and right direction of rotation, and a 1/4" bit magnetic holder. The product includes 1 x 2.0 Ah Battery, a Battery Charger, and Case.

Main features:

LED work light
Magnetic bit holder
Ergonomically shaped rubber handle

Technical specifications

| | |
|----------------------------|---|
| Order Number | XT102760E |
| Voltage | 18 V |
| Speed | 0-2,800 rpm |
| Max. torque | 180 Nm |
| Number of BPM | 0-3,600 BPM |
| Clamping | 1/4" |
| Sound pressure level (LpA) | 99 dB |
| Sound power level (LwA) | 110 dB |
| Other features | Left/right direction, LED work light, magnetic bit holder, electronic speed regulation |
| Product includes | 2x Battery pack 2.0 Ah, charger 2.4 A, driver bit PZ1, box |
| Weight without battery | 1.2 kg |



EVE





CORDLESS IMPACT WRENCH 18 V, BRUSHLESS

WITHOUT BATTERY

The Cordless Impact Wrench offers a three-level adjustable torque with a maximum torque of 300Nm. Comfortable operation due to an ergonomic, rubber handle and a compact construction. The Battery and Battery Charger not included. It is possible to purchase individual batteries and chargers.

Main features:

- 3 torque level modes
- LED work light

BRUSHLESS

Technical specifications

| | |
|----------------------------|--|
| Order Number | XT102830 |
| Voltage | 18 V |
| Speed | 0-1,000 / 0-1,800 / 0-2,700 rpm |
| Max. torque | 120 / 180 / 300 Nm |
| Number of BPM | 0-1,400 / 0-2,520 / 0-3,780 BPM |
| Clamping | 1/2" |
| Sound pressure level (LpA) | 69 dB |
| Sound power level (LwA) | 80 dB |
| Weight without battery | 1.15 kg |



BRUSHLESS

Main features:

- longer engine life
- higher power/torque
- lower weight
- maintenance-free operation



The future definitely lies in BRUSHLESS tools, which provide higher performance, lower weight and longer service life without the need for maintenance. We are constantly developing and improving our portfolio of cordless products, because we wish to offer our customers only the best and highest quality products at a fair price.



Born for outstanding projects.



CORDLESS ANGLE GRINDER 18 V, 115 mm

WITHOUT BATTERY

The Cordless 115mm Angle Grinder is designed for a great number of various cutting and grinding operations. A three-position adjustable handle provides a better operation control. The Battery and Battery Charger not included. It is possible to purchase individual batteries and chargers.

Main features:

- Ergonomically shaped rubber handle
- Three positions for handle setting

Technical specifications

| | |
|----------------------------|------------------------------------|
| Order Number | XT102720 |
| Voltage | 18 V |
| Speed | 10,000 rpm |
| Cutting blade diameter | 115 mm |
| Spindle thread | M14 |
| Sound pressure level (LpA) | 85 dB |
| Sound power level (LwA) | 96 dB |
| Other features | electronic speed regulation |
| Product includes | Key, handle |
| Weight without battery | 1.6 kg |

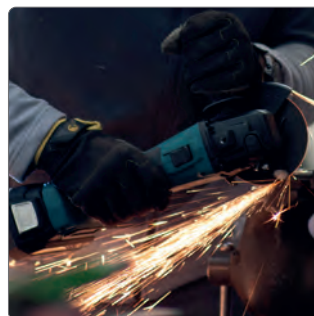



CORDLESS ANGLE GRINDER 18 V, 125 mm BRUSHLESS

WITHOUT BATTERY

The Brushless Cordless Angle Grinder allows longer operation with the use of a single battery charge. Comfortable operation due to an ergonomic, rubber handle and a compact construction. The Battery and Battery Charger not included. The BRUSHLESS motor benefits from long service life, higher performance/torque, lower weight, and maintenance-free operation. It is possible to purchase individual batteries and chargers.

Main features:

- Ergonomically shaped rubber handle
- Three positions for handle setting

BRUSHLESS



Technical specifications

| | |
|----------------------------|--|
| Order Number | XT102835 |
| Voltage | 18 V |
| Speed | 10,000 rpm |
| Cutting blade diameter | 125 mm |
| Spindle thread | M14 |
| Sound pressure level (LpA) | 75.8 dB |
| Sound power level (LWA) | 86.8 dB |
| Other features | Thermal fuse, electronic speed regulation |
| Product includes | Key, handle |
| Weight without battery | 1.6 kg |





CORDLESS MULTI-TOOL 18 V WITHOUT BATTERY

The Cordless Oscillating Multi-Tool cuts drywall, metal, wood, plastics, composite materials, and other various materials. It is capable of fine grinding too. The lever provided does not require any additional tool and a magnetic buckle allows fast and easy accessory replacement. Speed regulation, quick-release system, dust extraction, and LED work light that ensures good workpiece lighting and visibility. The Battery and Battery Charger not included. It is possible to purchase individual batteries and chargers.

Main features:

- LED work light
- 6-stage speed regulation according to the material type
- Quick-release system for quick tool change

Technical specifications

| | |
|----------------------------|---|
| Order Number | XT102725 |
| Voltage | 18 V |
| Speed | 5,000-20,000 rpm |
| Speed regulation | YES (position 1 - 6) |
| Sound pressure level (LpA) | 96.8 dB |
| Sound power level (LwA) | 107.8 dB |
| Other features | keyless clamping system, LED work light, electronic speed regulation |
| Product includes | 6pcs accessory kit |
| Weight without battery | 1.2 kg |





CORDLESS RANDOM ORBIT SANDER 18 V

WITHOUT BATTERY

The Cordless Random Orbit Sander provides an excellent ergonomic construction with two surfaces of soft, rubber Softgrip inserts that offer various handling and gripping positions. The Sander is designed for dry wood sanding, grinding of paints, and dry polishing. Six-level adjustable speed regulation. Dustproof trigger and eight dust extraction holes. The Battery and Battery Charger not included. It is possible to purchase individual batteries and chargers.

Main features:

- Six-level speed adjustment
- Dust bag extraction



Technical specifications

| | |
|----------------------------|---|
| Order Number | XT102740 |
| Voltage | 18 V |
| Speed | 2,000-10,000 rpm |
| Speed regulation | YES (position 1 - 6) |
| Cutting blade diameter | 125 mm |
| Sound pressure level (LpA) | 87 dB |
| Sound power level (LwA) | 98 dB |
| Other features | Speed regulation, dust extraction in bag |
| Weight without battery | 1.1 kg |





CORDLESS BELT SANDER 18 V WITHOUT BATTERY

The Cordless Belt Sander is suitable for sanding wood and metal in hard-to-reach areas. Comfortable operation is guaranteed due to a trigger lock. A dust extraction bag is included. It is possible to purchase individual batteries and chargers.

Main features:

- Manual adjustment with an accuracy of a millimeter
- Ergonomically shaped rubber handle
- Dust extraction attachment

Technical specifications

| | |
|----------------------------|---|
| Order Number | XT102755 |
| Voltage | 18 V |
| Speed | 120-380 rpm |
| Speed regulation | YES (position 1 - 6) |
| Sanding belt dimensions | 75x457 mm |
| Sanding area | 75x457 mm |
| Sound pressure level (LpA) | 87 dB |
| Sound power level (LwA) | 98 dB |
| Other features | Speed adjusting switch, dust extraction bag |
| Product includes | Dust bag |
| Weight without battery | 2.4 kg |





CORDLESS PLANER 18 V WITHOUT BATTERY

The Cordless Planer is suitable especially for working with wood. A powerful motor provides longer operation with the use of a single battery charge. The Planer benefits from an ergonomic handle that allows comfortable operation. Depth settings from 0 to 1.5mm. The Battery and Battery Charger not included. It is possible to purchase individual batteries and chargers.

Main features:

- Dust extraction attachment
- Ergonomically shaped rubber handle
- Cutting depth adjustment from 0 to 1.5mm

Technical specifications

| | |
|----------------------------|---|
| Order Number | XT102750 |
| Voltage | 18 V |
| Speed | 14,000 rpm |
| Počet noží | 2 |
| Adjustable cutting height | 0-1.5 mm |
| Plane width | 82 mm |
| V-groove width | 5 mm |
| Chamfer groove depth | 0-18 mm |
| Product size | 305x170x180 mm |
| Sound pressure level (LpA) | 84 dB |
| Sound power level (LwA) | 95 dB |
| Other features | Electronic speed regulation, dust extraction bag |
| Product includes | Dust bag, guide rail, allen key |
| Weight without battery | 2.3 kg |

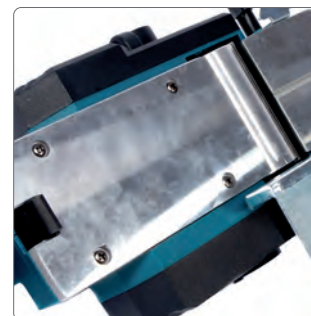



CORDLESS CIRCULAR SAW 18 V, 165 mm

WITHOUT BATTERY

The Cordless Circular Saw is designed for cutting wood materials, adjustable for various cutting angles for precise material joinery. A motor brake, rubber handle for safer operation, dust extraction attachment, laser switch, laser marker for precise cutting, depth and angle regulation, and easy control. The Battery and Battery Charger not included. It is possible to purchase individual batteries and chargers.

Main features:

- Dust extraction attachment
- Electronic motor brake
- Rubber handle for safe operation
- Laser marker

Technical specifications

| | |
|------------------------------|-------------------|
| Order Number | XT102745 |
| Voltage | 18 V |
| Speed | 4,200 rpm |
| Cutting capacity at 90°/ 45° | 51 / 35 mm |
| Miter cut | 0°-45° |
| Cutting blade diameter | 165 mm |
| Disc clamping | 20 mm |
| Sound pressure level (LpA) | 80 dB |
| Sound power level (LwA) | 91 dB |
| Other features | laser |
| Product includes | Guide |
| Weight without battery | 2.4 kg |





CORDLESS CIRCULAR SAW 18 V, 165 mm BRUSHLESS

WITHOUT BATTERY

The Cordless Circular Saw is designed for cutting wood materials, adjustable for various cutting angles for precise material joinery. The Saw is equipped with a laser guide for precise cutting. The BRUSHLESS motor benefits from long service life, higher performance/torque, lower weight, and maintenance-free operation. The Battery and Battery Charger not included. It is possible to purchase individual batteries and chargers.

Main features:

- Dust extraction attachment
- Electronic motor brake
- Rubber handle for safe operation
- Laser marker

BRUSHLESS



Technical specifications

| | |
|------------------------------|-------------------|
| Order Number | XT102845 |
| Voltage | 18 V |
| Speed | 4,200 rpm |
| Cutting capacity at 90°/ 45° | 51 / 35 mm |
| Miter cut | 0°-45° |
| Cutting blade diameter | 165 mm |
| Disc clamping | 20 mm |
| Sound pressure level (LpA) | 75.8 dB |
| Sound power level (LwA) | 86.8 dB |
| Other features | laser |
| Product includes | Guide |
| Weight without battery | 2.4 kg |

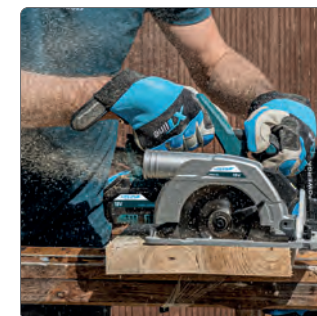



CORDLESS JIG SAW 18 V WITHOUT BATTERY

The Cordless Jig Saw is designed for straight cutting of wood, Aluminum, and steel. Compact and light construction and small handle circumference allow optimal cutting control. A high-performance battery system allows cutting of harder and thicker materials. Fast and easy saw blade replacement. On/Off sawdust extraction system, pendulum action adjustment up to 4 degrees. The Battery and Battery Charger not included. It is possible to purchase individual batteries and chargers.

Main features:

- Quick-release system for saw blade replacement
- Sawdust extraction On/Off switch
- LED work light
- Guide

Technical specifications

| | |
|----------------------------|---|
| Order Number | XT102735 |
| Voltage | 18 V |
| Speed | 0-2,700 rpm |
| Speed regulation | YES (position 1 - 6) |
| Max. cutting capacity | metal 5 mm, wood 80 mm, aluminum 12 mm |
| Miter cut | 0°-45° |
| Clamping | T-type |
| Sound pressure level (LpA) | 79.4 dB |
| Sound power level (LwA) | 90.4 dB |
| Other features | LED work light, keyless clamping system, electronic speed regulation |
| Product includes | 2x saw blade |
| Weight without battery | 1.7 kg |





Born for outstanding projects.



CORDLESS RECIPROCATING SAW 18 V

WITHOUT BATTERY

The Cordless Reciprocating Saw is designed for cutting in hard-to-reach areas. It offers better stability and easy manipulation due to motor positioning. A perfect tool for plumbers and other craftsmen. Adjustable depth-stop, a saw blade quick-release system, and pendulum action adjustment. The Battery and Battery Charger not included. It is possible to purchase individual batteries and chargers.

Main features:

- Better access in hard-to-reach areas
- Quick-release system for saw blade replacement

Technical specifications

| | |
|----------------------------|---|
| Order Number | XT102730 |
| Voltage | 18 V |
| Speed | 0-3,000 rpm |
| Max. cutting capacity | metal 10 mm, wood 115 mm |
| Sound pressure level (LpA) | 82 dB |
| Sound power level (LwA) | 93 dB |
| Other features | keyless clamping system, electronic speed regulation |
| Product includes | 2x saw blade |
| Weight without battery | 1.7 kg |



CORDLESS RECIPROCATING SAW 18 V, BRUSHLESS

WITHOUT BATTERY

The Cordless Reciprocating Saw is designed for cutting in hard-to-reach areas. It offers better stability and easy manipulation due to motor positioning. A perfect tool for plumbers and other craftsmen. Adjustable depth-stop, a saw blade quick-release system, and pendulum action adjustment. The Battery and Battery Charger not included. It is possible to purchase individual batteries and chargers.

Main features:

BRUSHLESS

- Better access to hard-to-reach places
- Quick-release system for saw blade replacement
- Electronic speed control
- Pendulum action adjustment



Technical specifications

| | |
|----------------------------|---|
| Order Number | XT102850 |
| Voltage | 18 V |
| Speed | 0-3,100 rpm |
| Max. cutting capacity | metal 10 mm, wood 120 mm |
| Sound pressure level (LpA) | 79 dB |
| Sound power level (LwA) | 90 dB |
| Other features | Keyless clamping system, pendulum mode switch, electronic speed regulation |
| Product includes | 1x saw blade for wood / metal |
| Weight without battery | 1.7 kg |





CORDLESS COMPRESSOR 18 V WITHOUT BATTERY

The Cordless Air Compressor is designed for inflating tires and sports equipment. A gun shape with an ergonomic handle that allows comfortable operation. LCD manometer display, and air hose holder. The Battery and Battery Charger not included. It is possible to purchase individual batteries and chargers.

Main features:

- LCD display
- Gun-shaped ergonomic handle for comfortable operation
- Accessories

Technical specifications

| | |
|----------------------------|-----------------------------------|
| Order Number | XT102775 |
| Voltage | 18 V |
| Max. pressure | 7 bar |
| Sound pressure level (LpA) | 80.5 dB |
| Sound power level (LwA) | 90 dB |
| Product includes | Hose with fittings, hose adapters |
| Weight without battery | 0.7 kg |



CORDLESS FLASHLIGHT 18 V, 3 W

WITHOUT BATTERY

The Cordless Flashlight is equipped with 3W high-quality LED lights. Diodes provide a wide lighting angle of 90° and a great luminous flux of 260 lumens. Variable rotatable 90° head - 4 levels of settings. The Battery and Battery Charger not included. It is possible to purchase individual batteries and chargers.

Main features:

Low weight and compact

Technical specifications

| | |
|------------------------|---|
| Order Number | XT102765 |
| Voltage | 18 V |
| Input power | 3 W |
| Luminosity | 260 lm |
| Other features | Variable rotatable head - 4 stages |
| Weight without battery | 0.3 kg |
| Order Number | XT102768 |
| Voltage | 18 V |
| Input power | 35 W |
| Work duration | with 2.0 Ah battery pack - 60 min (max. performance) |
| Luminosity | 2000 / 5000 lm |
| Radiation angle | 120° |
| Other features | Adjustable angle position, two lu- minosity modes |
| Weight without battery | 0.9 kg |



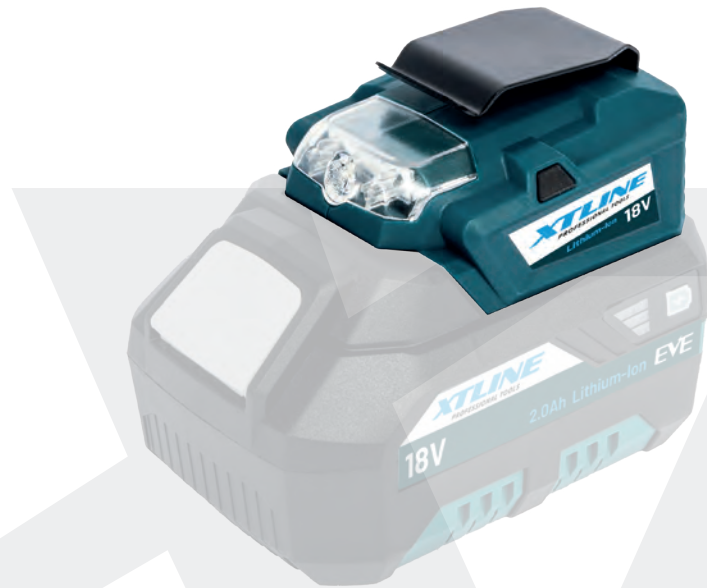

CHARGER WITH LED LIGHT, 18 V

WITHOUT BATTERY

The Charger is used for recharging electronic devices. The charger offers USB output and LED light. It is supplied without battery. It is possible to purchase individual batteries and chargers.

Main features:

USB charging interface.



Technical specifications

| | |
|---------------------|-------------------|
| Order Number | XT102795 |
| Voltage | 18 V |
| Input power | 0,3 W |
| Luminosity | 60 lm |
| Output voltage | 5 V |
| Charging current | 1.5 A |
| Other features | USB port charging |
| Weight | 0.1 kg |



CORDLESS CHAIN SAW 36 V, BRUSHLESS

WITHOUT BATTERY

The cordless chainsaw is designed for cutting, shortening firewood, construction lumber or trimming branches. Tool-free chain replacement. The Oregon chain and bar with a length of 350 mm provide a sufficiently long cross-section of the wooden material of up to 260 mm. It is possible to purchase individual batteries and chargers.

Main features:

- Safety brake
- Key-less chain replacement
- Automatic bar lubrication

BRUSHLESS

Technical specifications

| | |
|----------------------------|--|
| Order Number | XT102870 |
| Voltage | 36 V |
| Speed | 10,000 rpm |
| Chain speed | 0-19 m/s |
| Bar length | 350 mm |
| Bar thickness | 1.3 mm |
| Chain pitch | 3/8" |
| Number of links | 52 |
| Sound pressure level (LpA) | 91.6 dB |
| Sound power level (LwA) | 101.4 dB |
| Other features | Automatic chain lubrication, safety brake |
| Weight without batteries | 4 kg |
| Order Number | XT102870-2B4 |
| Product includes | 2x Battery pack 4.0 Ah, charger 2x18 V, 3.0 A |





CORDLESS HEDGE TRIMMER 36 V

WITHOUT BATTERY

The cordless hedge trimmer is powered by two 18 V Li-ion batteries with a total voltage of 36 V. It is intended for cutting hedges, bushes, and thuja trees. The advantage is the two-handed switch, which prevents accidental starting of the scissors. It is possible to purchase individual batteries and chargers.

Main features:

- Protective cover
- Safety brake
- Possibility to adjust the handle at a 45°/90° inclination (right and left)

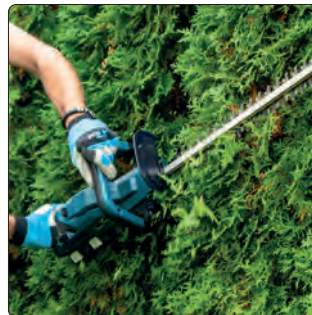
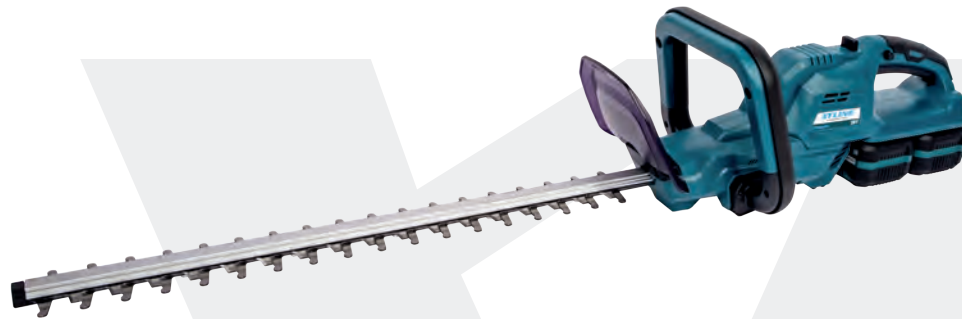

Technical specifications

| | |
|--------------------------|---|
| Order Number | XT102875 |
| Voltage | 36 V |
| Speed | 2,700 rpm |
| Bar length | 600 mm |
| Tooth pitch | 24 mm |
| Other features | Protective shield, rotatable handle 45° / 90°, safety brake |
| Weight without batteries | 3.7 kg |
| Order Number | XT102875-2B2 |
| Product includes | 2x Battery pack 2.0 Ah, charger 3.5 A |



CORDLESS STRING TRIMMER 2 IN 1, 36 V, BRUSHLESS

WITHOUT BATTERY

The cordless string trimmer is powered by two 18 V Li-ion batteries with a total voltage of 36 V. It copes well with cutting tall grass, but it can also get to hard-to-reach spots. The 2in1 function allows fitting either a string head or a three-tooth cutting blade. The batteries and motor located at the back serve for better balance and weight distribution. The trimmer has a reverse button to unwind the grass. It is possible to purchase individual batteries and chargers.

Main features:

BRUSHLESS

- 2 in 1 - string head / three-tooth cutting blade
- Reverse button for unwinding jammed grass

Technical specifications

| | |
|--------------------------|---|
| Order Number | XT102895 |
| Voltage | 36 V |
| Speed | 0-6,500 rpm |
| Max. string diameter | 2 mm |
| Cutting width | 350 mm (knife) / 250 mm (string) |
| Work duration | with 5.0 Ah battery packs - 60 min |
| Clamping | string head / 3-tooth cutting blade |
| Other features | Reverse switch to unwind jammed grass, adjustable handle |
| Product includes | String head with spring, 3-tooth cutting blade, shoulder strap |
| Weight without batteries | 4.3 kg |
| Order Number | XT102895-2B4 |
| Product includes | 2x Battery pack 4.0 Ah, charger 3.0 A |

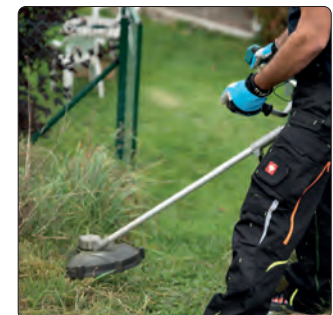



CORDLESS STRING TRIMMER 18 V

WITHOUT BATTERY

The cordless string mower is used for trimming the edges of lawns. Its low weight in combination with a telescopic handle and a reach of 280 mm ensure excellent comfort during work. It is possible to purchase individual batteries and chargers.

Main features:

- Adjustable telescopic handle
- Low weight

Technical specifications

| | |
|----------------------------|--|
| Order Number | XT102910 |
| Voltage | 18 V |
| Speed | 9,000 rpm |
| Max. string diameter | 1.6 mm |
| Cutting width | 280 mm |
| Clamping | string head |
| Sound pressure level (LpA) | 72 dB |
| Sound power level (LWA) | 96 dB |
| Other features | adjustable handle, rotatable head 90° |
| Weight without battery | 2 kg |
| Order Number | XT102910-1B2 |
| Product includes | 1x Battery pack 2.0 Ah + charger 2.4 A |





CORDLESS STRING TRIMMER

36 V

WITHOUT BATTERY

The Cordless Mower is powered by two Li-Ion 18 V batteries with a total voltage of 36 V. It is intended for trimming around fences, draws, thuja, etc. It has an adjustable handle, where you can set the optimal height. It is possible to purchase individual batteries and chargers.

Main features:

- String head adjustment in six levels
- Additional handle for easy operation
- Rotatable 90° head
- Support wheel for trimming lawn edges



Technical specifications

| | |
|--------------------------|--|
| Order Number | XT102880 |
| Voltage | 36 V |
| Speed | 6,700 rpm |
| Max. string diameter | 1.6 mm |
| Cutting width | 300 mm |
| Total length | 1,520 mm |
| Other features | Rotatable head 90°, automatic string feed |
| Weight without batteries | 3.8 kg |
| Order Number | XT102880-2B2 |
| Product includes | 2x Battery pack 2.0 Ah, charger 3.5 A |

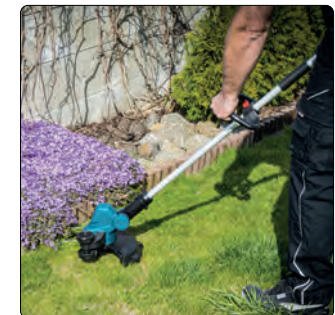



CORDLESS LAWN MOWER 36 V, 405 mm BRUSHLESS

WITHOUT BATTERY

The Cordless Lawn Mower is a powerful, BRUSHLESS motor machine powered by two Li-ion 18 V batteries with a total voltage of 36 V. It provides a very quiet operation. Possible to use 2.0 Ah, and 4.0 Ah batteries. Cutting and collection system. The Lawn Mower is designed for cutting smaller, maintained areas (approx. 600m²). Cutting height settings – 25mm to 75mm. Operation time approximately 1 hour with the use of 4.0 Ah batteries, provided the grass is dry. The battery and Battery Charger not included. It is possible to purchase individual batteries and chargers.

Main features:

BRUSHLESS

- Six-level cutting height adjustment
- 40L grass collection box
- Side discharge

Technical specifications

| | |
|--------------------------|--|
| Order Number | XT102890 |
| Voltage | 36 V |
| Input power | 800 W |
| Speed | 3,600 rpm |
| Wheel diameter | 17.5 / 25 cm |
| Cutting width | 405 mm |
| Basket volume | 40 l |
| Other features | Electric brake, 6-level adjustable cutting height, safety key |
| Weight without batteries | 15 kg |
| Order Number | XT102890-2B4 |
| Product includes | 2x Battery pack 4.0 Ah, charger 2x18 V, 3.0 A |





CORDLESS GARDEN VACUUM CLEANER 36 V

WITHOUT BATTERY

The Cordless Garden Vacuum Cleaner is designed for vacuuming garden leaves, blowing of garden impurities without the use of the electricity source. The low tool weight allows easy manipulation and comfortable garden clean-up. It is possible to purchase individual batteries and chargers.

Main features:

- Speed control
- 2 in 1 system - vacuuming and blowing function

Technical specifications

| | |
|----------------------------|---|
| Order Number | XT102935 |
| Voltage | 36 V |
| Speed | 26,000 rpm |
| Sack volume | 35 l |
| Air speed | 245 m/s |
| Waste shredding | 9:1 |
| Sound pressure level (LpA) | 97 dB |
| Sound power level (LwA) | 106 dB |
| Other features | Speed adjusting switch, vacuum cleaner / blower mode switch |
| Product includes | Dust bag, shoulder strap, roller wheel, vacuum cleaner tube, blower tube |
| Weight without batteries | 2.8 kg |
| Order Number | XT102935-2B4 |
| Product includes | 2x Battery pack 4.0 Ah, charger 3.0 A |





CORDLESS BACK SPRAYER 18 V

WITHOUT BATTERY

The Cordless Backpack Sprayer is suitable for treating garden trees, bushes, or plants. Specifically shaped tank and wide straps provide comfortable operation. It is possible to purchase individual batteries and chargers.

Main features:

- Waterproof switch
- Replacement nozzles

Technical specifications

| | |
|----------------------------|---|
| Order Number | XT102940 |
| Voltage | 18 V |
| Vessel volume | 10 l |
| Max. pressure | 3 bar |
| Spray rod length | 800 mm |
| Max. flow | 1.3 l/min |
| Product size | 200x310x480 mm |
| Sound pressure level (LpA) | 72.8 dB |
| Sound power level (LwA) | 82.8 dB |
| Other features | Waterproof switch |
| Product includes | Back strap, 3x nozzle |
| Weight without battery | 2.8 kg |
| Order Number | XT102940-1B2 |
| Product includes | 1x Battery pack 2.0 Ah + charger 2.4 A |



LI-ION BATTERY CHARGERS

18 V

2.4 / 3.5 A

The Charger is designed for charging Li-Ion batteries.

Main features:

Compatible with all XTLINE 18 V Li-Ion battery packs
LED indication



Technical specifications

| | |
|---------------------|-------------------------|
| Order Number | XT102785 |
| Voltage | 18 V |
| Input power | 65 W |
| Output voltage | 21.5 V |
| Charging current | 2.4 A |
| Other features | LED capacity indication |
| Weight | 0.4 kg |
| Order Number | XT102790 |
| Voltage | 18 V |
| Input power | 85 W |
| Output voltage | 21.5 V |
| Charging current | 3.5 A |
| Other features | LED capacity indication |
| Weight | 0.4 kg |





LI-ION BATTERY CHARGER 2x 18 V, 3.0 A

The Charger is designed for charging Li-Ion batteries.

Main features:

- Charging of two battery packs simultaneously
- Compatible with all XTLINE 18 V Li-Ion battery packs
- LED indication



Technical specifications

| | |
|------------------|--------------------------------|
| Order Number | XT102792 |
| Voltage | 18 V |
| Input power | 160 W |
| Output voltage | 21.5 V |
| Charging current | 3.0 A |
| Other features | LED capacity indication |
| Weight | 0.6 kg |



BATTERY PACK LI-ION 18 V

EVE

Suitable for Li-Ion battery-powered tools only. The battery is powered by EVE battery cells that ensure great performance and service life. The battery is equipped with a battery capacity level indication.

Main features:

- Rubber surface
- Battery capacity indication
- Compatible with all 18 V/36 V cordless tools.

Technical specifications

| | |
|---------------------|-------------------------|
| Order Number | XT102782E |
| Voltage | 18 V |
| Battery capacity | 2.0 Ah |
| Other features | LED capacity indication |
| Weight | 0.4 kg |
| Order Number | XT102784E |
| Voltage | 18 V |
| Battery capacity | 4.0 Ah |
| Other features | LED capacity indication |
| Weight | 0.7 kg |
| Order Number | XT102786E |
| Voltage | 18 V |
| Battery capacity | 5.0 Ah |
| Other features | LED capacity indication |
| Weight | 0.8 kg |
| Order Number | XT102787E |
| Voltage | 18 V |
| Battery capacity | 6.0 Ah |
| Weight | 1 kg |



EVE



CORDLESS RECIPROCATING SAW 18 V

Order Number **XT102730-1B2B**

Product includes 1x Battery pack 2.0 Ah, Charger 3.5 A, box



CORDLESS JIG SAW 18 V

Order Number **XT102735-1B2B**

Product includes 1x Battery pack 2.0 Ah, charger 3.5 A, box, saw blade set



CORDLESS PLANER 18 V

Order Number **XT102750-1B5B**

Product includes 1x Battery pack 5.0 Ah, charger 3.5 A, box



CORDLESS ANGLE GRINDER 18 V, 125 mm BRUSHLESS

Order Number **XT102835-1B5B**

Product includes 1x Battery pack 5.0 Ah, charger 3.5 A, box, 5x cutting disc (stainless-steel), 1x cutting disc (steel)



BRUSHLESS

CORDLESS ROTARY HAMMER 18 V, BRUSHLESS, SDS PLUS

Order Number **XT102840-1B5B**

Product includes 1x Battery pack 5.0 Ah, charger 3.5 A, box



BRUSHLESS

CORDLESS CIRCULAR SAW 165 MM, 18 V, BRUSHLESS

Order Number **XT102845-1B5B**

Product includes 1x Battery pack 5.0 Ah, charger 3.5 A, box



BRUSHLESS

CORDLESS JIG SAW 18 V

BRUSHLESS

) brushless motor



QUICK CHARGER FOR LI-ION BATTERIES 18 V

SMART CHARGER

) setting the current and charging time for a specific type of battery



COMING SOON

CORDLESS MINI-CHAIN SAW 18 V

GARDEN TOOL

) easy trimming of tree branches



CORDLESS GARDEN TOOL SET 18 V

3 PARTS

) 3 attachments

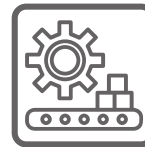

XTLINE
PROFESSIONAL TOOLS

BATTERY LI-ION 18 V

SAMSUNG

) improved cells / compact design

) battery capacity 4.0, 8.0 Ah





XTLINE
PROFESSIONAL TOOLS

XTLINE

XTLINE

230 V

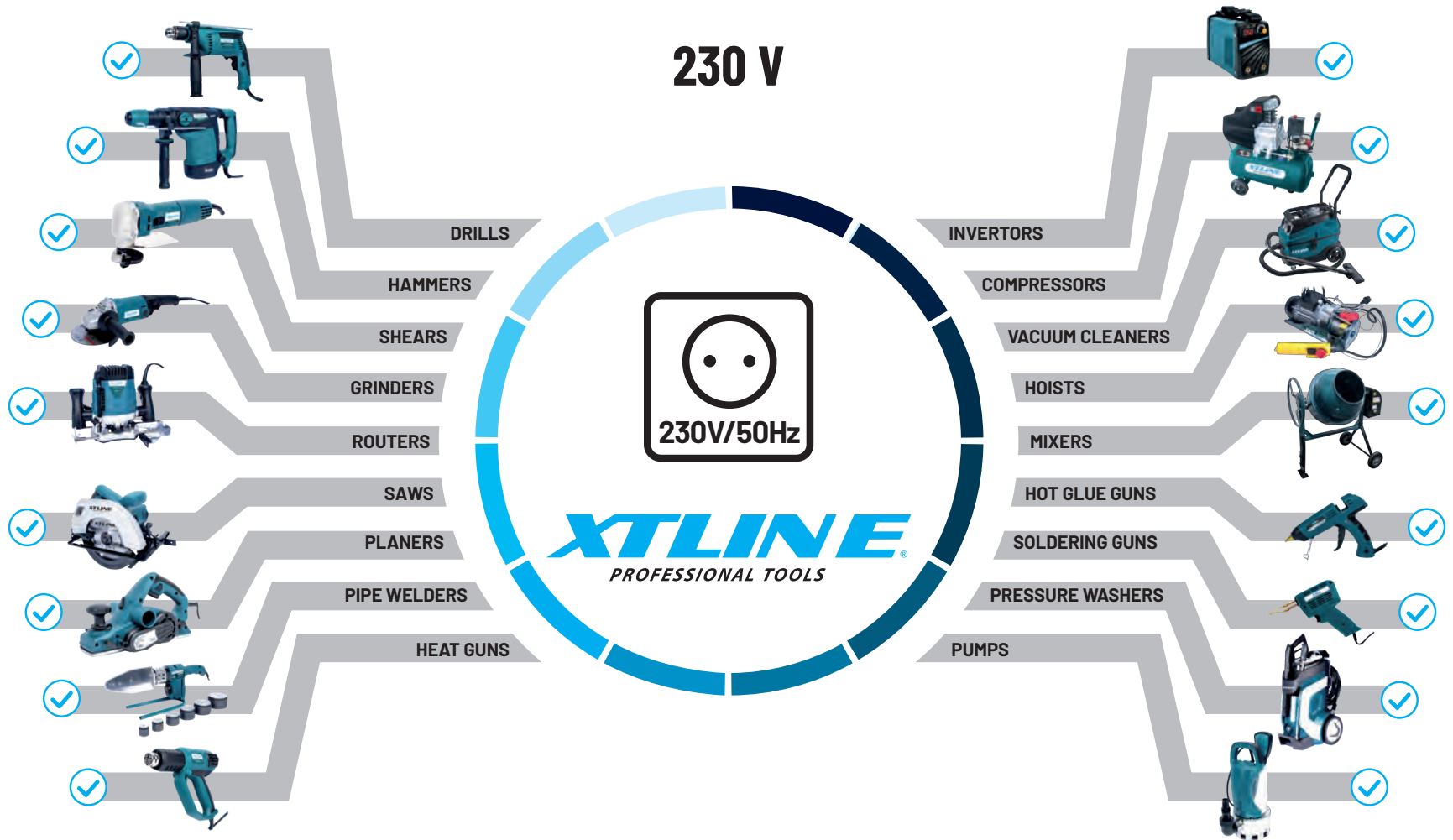

ELECTRO

Our range of power tools offers products for almost all common crafts. Whether you need screwdrivers, drills, rotary hammers, grinders, saws, milling machines, routers, compressors, vacuum cleaners, pumps and many other types of tools for your work, you can surely find the best match. Quality processed and certified products are created to serve you and to complete all of your great projects.

Born for outstanding projects.



HAMMER DRILL 850 W

The Hammer Drill with a metal chuck is designed for precise drilling. It allows convenient drilling in all materials including construction materials due to the hammer drill mode. The Drill is easy to control due to large-sized switches, the direction of rotation switch, and continuous speed regulation – all situated on the handle. The Drill benefits from a powerful motor for drilling/hammer drilling, continuous speed regulation according to the material type, low weight, compact design, and high torque.

Main features:

Continuous speed regulation
Mode selector: drilling / hammer drilling

Technical specifications

| | |
|----------------------------|--|
| Order Number | XT106120 |
| Voltage | 230V/50Hz |
| Input power | 850 W |
| Speed | 0-3,000 rpm |
| Max drilling diameter | metal 13 mm, wood 30 mm, concrete 16 mm |
| Drill bit diameter | 1.5-13 mm |
| Clamping | chuck |
| Sound pressure level (LpA) | 95.4 dB |
| Sound power level (LwA) | 106.4 dB |
| Other features | Left/right direction, speed regulation |
| Product includes | Handle, depth stop, a pair of carbon brushes, chuck key |
| Weight | 2.3 kg |



HAMMER DRILL 900 W

The Hammer Drill with a metal chuck is designed for precise drilling. It allows convenient drilling in all materials including construction materials due to the hammer drill mode. The Drill is easy to control due to large-sized switches, the direction of rotation switch, and continuous speed regulation – all situated on the handle. The Drill benefits from a powerful motor for drilling/hammer drilling, continuous speed regulation according to the material type, low weight, compact design, and high torque.

Main features:

- Continuous speed regulation
- Mode selector: drilling / hammer drilling
- Metal body

Technical specifications

| | |
|----------------------------|--|
| Order Number | XT106130 |
| Voltage | 230V/50Hz |
| Input power | 900 W |
| Speed | 0-2,800 rpm |
| Max drilling diameter | metal 13 mm, wood 30 mm, concrete 16 mm |
| Drill bit diameter | 1.5-13 mm |
| Clamping | chuck |
| Sound pressure level (LpA) | 95.4 dB |
| Sound power level (LwA) | 106.4 dB |
| Other features | Left/right direction, speed regulation |
| Product includes | Handle, depth stop, a pair of carbon brushes, chuck key |
| Weight | 2.5 kg |





HAMMER DRILL 1050 W

The Hammer Drill with a metal chuck is designed for precise drilling. It allows convenient drilling in all materials including construction materials due to the hammer drill mode. The Drill is easy to control due to large-sized switches, the direction of rotation switch, and continuous speed regulation – all situated on the handle. The Drill benefits from a powerful motor for drilling/hammer drilling, continuous speed regulation according to the material type, low weight, compact design, and high torque.

Main features:

- Continuous speed regulation
- Mode selector: drilling / hammer drilling
- The two-speed gearbox
- Metal body

Technical specifications

| | |
|----------------------------|--|
| Order Number | XT106150 |
| Voltage | 230V/50Hz |
| Input power | 1050 W |
| Speed | 0-1,200 / 0-3,000 rpm |
| Max drilling diameter | metal 13 mm, wood 40 mm, concrete 16 mm |
| Drill bit diameter | 1.5-13 mm |
| Speed control positions | 2 |
| Clamping | chuck |
| Sound pressure level (LpA) | 70 dB |
| Sound power level (LwA) | 80 dB |
| Other features | Left/right direction, speed regulation |
| Product includes | Handle, depth stop, a pair of carbon brushes, chuck key |
| Weight | 3.2 kg |



ROTARY HAMMER 850 W, SDS PLUS, 3 J

The Rotary Hammer for SDS PLUS drill bits. Designed for construction operations (concrete, stone, bricks, etc.)

Main features:

Low weight
Mode selector: drilling / hammer drilling / chisel rotation / chiseling

Technical specifications

| | |
|----------------------------|--|
| Order Number | XT106005 |
| Voltage | 230V/50Hz |
| Input power | 850 W |
| Speed | 0-1,300 rpm |
| Number of BPM | 0-4,300 BPM |
| Impact energy | 3 J |
| Max drilling diameter | metal 13 mm, wood 30 mm, concrete 28 mm |
| Drilling/chiselling ratio | 80 / 20 % |
| Functions | drilling, hammer drilling, chiselling and lock-position |
| Clamping | SDS PLUS |
| Sound pressure level (LpA) | 91 dB |
| Sound power level (LwA) | 102 dB |
| Product includes | Drill bit (6, 8, 10/150mm), point chisel, flat chisel, lubrication, box |
| Weight | 3.2 kg |





ROTARY HAMMER 850 W, SDS PLUS, 3 J

+ ACCESSORY KIT

The Rotary Hammer with replaceable chuck for SDS PLUS drill bits. Designed for construction operations (concrete, stone, bricks, etc.)

Main features:

- Fast SDS PLUS chuck replacement
- Low weight
- Mode selector: drilling / hammer drilling / chisel rotation / chiselling
- Extra chuck (cylindrical shank clamping)

Technical specifications

| | |
|----------------------------|--|
| Order Number | XT106010 |
| Voltage | 230V/50Hz |
| Input power | 850 W |
| Speed | 0-1,300 rpm |
| Number of BPM | 0-4,300 BPM |
| Impact energy | 3 J |
| Max drilling diameter | metal 13 mm, wood 30 mm, concrete 28 mm |
| Drilling/chiselling ratio | 80 / 20 % |
| Functions | drilling, hammer drilling, chiselling and lock-position |
| Clamping | SDS PLUS |
| Sound pressure level (LpA) | 91 dB |
| Sound power level (LwA) | 102 dB |
| Product includes | 3x drill bit, point chisel, flat chisel, spare chuck, box |
| Weight | 3.2 kg |





ROTARY HAMMER 1000 W, SDS PLUS, 3.5 J

The Rotary Hammer is suitable for drilling and cutting of masonry and concrete, chiseling plasters, tiling, drilling anchor and through holes, and core drilling. A mode switch adjustable at drilling, hammer drilling, and chiseling position. 3-stage clutch as protection against tool spinning.

Main features:

Mode selector: hammer drilling / chiseling
LED indicator/button - speed adjustment

Technical specifications

| | |
|----------------------------|---|
| Order Number | XT106040 |
| Voltage | 230V/50Hz |
| Input power | 1000 W |
| Speed | 650-1,000 rpm |
| Speed regulation | YES (low/medium/high) |
| Number of BPM | 2,800-3,400 BPM |
| Impact energy | 3.5 J |
| Max drilling diameter | metal 13 mm, wood 30 mm, concrete 28 mm, brick 80 mm |
| Drilling/chiselling ratio | 80 / 20 % |
| Functions | hammer drilling, chiselling |
| Clamping | SDS PLUS |
| Sound pressure level (LpA) | 93 dB |
| Sound power level (LwA) | 104 dB |
| Product includes | A pair of carbon brushes, lubrication, depth stop, box |
| Weight | 5 kg |





Made in Italy



ROTARY HAMMER 900 W, SDS PLUS, 6 J

The Rotary Hammer is suitable for drilling and cutting of masonry and concrete, chiseling plasters, tiling, drilling anchor and through holes, and core drilling. A mode switch adjustable at drilling, hammer drilling, and chiseling position.

Main features:

- Mode selector: hammer drilling / chiseling
- A powerful motor

Technical specifications

| | |
|----------------------------|---|
| Order Number | XT106050 |
| Voltage | 230V/50Hz |
| Input power | 900 W |
| Speed | 0-850 rpm |
| Number of BPM | 0-4,500 BPM |
| Impact energy | 6 J |
| Max drilling diameter | metal 15 mm, wood 45 mm, concrete 30 mm, brick 82 mm |
| Drilling/chiselling ratio | 80 / 20 % |
| Functions | hammer drilling, chiselling |
| Clamping | SDS PLUS |
| Sound pressure level (LpA) | 90 dB |
| Sound power level (LwA) | 103 dB |
| Product includes | A pair of carbon brushes, lubrication, depth stop, box |
| Weight | 5.1 kg |





ROTARY HAMMER 1100 W, SDS MAX, 7 J

The Rotary Hammer with an SDS-MAX locking system is designed for drilling and cutting with an angle-adjustment up to 12 positions. It is equipped with an anti-vibration system that decreases the fatigue during operation. It is used for construction materials – bricks, concrete, or stone.

Main features:

- 12-position chisel adjustment
- Anti-vibration system

Technical specifications

| | |
|----------------------------|---|
| Order Number | XT106061 |
| Voltage | 230V/50Hz |
| Input power | 1100 W |
| Speed | 300-760 rpm |
| Speed regulation | YES (position 1 - 6) |
| Number of BPM | 1,900-4,860 BPM |
| Impact energy | 1 - 7 J |
| Max drilling diameter | concrete 40 mm |
| Drilling/chiselling ratio | 80 / 20 % |
| Functions | hammer drilling, chiselling |
| Clamping | SDS MAX |
| Sound pressure level (LpA) | 90.8 dB |
| Sound power level (LwA) | 101.8 dB |
| Other features | Speed adjusting switch |
| Product includes | Lubrication, a pair of carbon brushes, depth stop, box |
| Weight | 6.1 kg |





DEMOLITION HAMMER 1200 W, SDS MAX, 7 J

The Demolition Hammer is used especially for demolition operations in households, but in the short term can be also used for professional operations. Softened handle zones allow longer fatigue-free and hand-sensitive operation. Designed for construction materials – bricks, concrete, or stone. Adjustable cutting angle due to the 12-position cutter selector. Ergonomic softened handle 360°, power indication, carbon brush wear protection, and anti-vibration system (lower operation fatigue).

Main features:

- 12-position chisel adjustment
- Anti-vibration system

Technical specifications

| | |
|----------------------------|--|
| Order Number | XT106057 |
| Voltage | 230V/50Hz |
| Input power | 1200 W |
| Speed | 300-760 rpm |
| Number of BPM | 1,900-3,100 BPM |
| Impact energy | 14 J |
| Functions | chiselling |
| Clamping | SDS MAX |
| Sound pressure level (LpA) | 90.8 dB |
| Sound power level (LwA) | 101.8 dB |
| Product includes | Point chisel, flat chisel, lubrication, a pair of carbon brushes, box |
| Weight | 5.6 kg |





SHEET METAL SHEARS 600 W

The Sheet Metal Shears are used for fast, chipless cutting and trimming of full or perforated steel and metal sheets made of non-ferrous metals. The tool allows fast and precise metal sheet cuts up to the thickness of 1.6mm.

Main features:

- Sheet metal cutting - thickness of up to 1.6mm
- Interchangeable blade



Technical specifications

| | |
|----------------------------|--|
| Order Number | XT106335 |
| Voltage | 230V/50Hz |
| Input power | 600 W |
| Speed | 4,500 rpm |
| Max. cutting capacity | 1,6 mm |
| Sound pressure level (LpA) | 78.9 dB |
| Sound power level (LwA) | 89.9 dB |
| Product includes | a pair of carbon brushes, allen key |
| Weight | 2.5 kg |





ANGLE GRINDER 720 W 115 mm

Use of an Angle Grinder in combination with a proper attachment allows more effective and faster cutting and grinding of metal and construction materials, grinding of welds, chamfering (roof tiles, metal prisms and bars, bricks, concrete, tiling). Construction and outer tool shell is dust-resistant and ensures long motor service life. The protective cover key-less adjustment. A slim, ergonomic body allows a comfortable tool grip and easy manipulation including hard-to-reach areas. A switch-lock for one-hand cutting and grinding.

Main features:

- Accidental start-up protection in the case of a power outage
- An ergonomic body
- A switch-lock for one-hand cutting and grinding
- Tool-free adjustable protective cover

Technical specifications

| | |
|----------------------------|---------------------------|
| Order Number | XT105115 |
| Voltage | 230V/50Hz |
| Input power | 720 W |
| Speed | 11,000 rpm |
| Cutting blade diameter | 115 mm |
| Spindle thread | M14 |
| Sound pressure level (LpA) | 83 dB |
| Sound power level (LwA) | 94 dB |
| Product includes | Key, handle, cover |
| Weight | 1.9 kg |





ANGLE GRINDER 840 W 125 mm

Use of an Angle Grinder in combination with a proper attachment allows more effective and faster cutting and grinding of metal and construction materials, grinding of welds, chamfering (roof tiles, metal prisms and bars, bricks, concrete, tiling). Construction and outer tool shell is dust-resistant and ensures long motor service life. The protective cover key-less adjustment. A slim, ergonomic body allows a comfortable tool grip and easy manipulation including hard-to-reach areas. A switch-lock for one-hand cutting and grinding.

Main features:

- Accidental start-up protection in the case of a power outage
- An ergonomic body
- A switch-lock for one-hand cutting and grinding



Technical specifications

| | |
|----------------------------|---------------------------|
| Order Number | XT105125 |
| Voltage | 230V/50Hz |
| Input power | 840 W |
| Speed | 10,000 rpm |
| Cutting blade diameter | 125 mm |
| Spindle thread | M14 |
| Sound pressure level (LpA) | 77 dB |
| Sound power level (LwA) | 88 dB |
| Product includes | Key, handle, cover |
| Weight | 2 kg |





ANGLE GRINDER 1200 W 150 MM

Use of an Angle Grinder in combination with a proper attachment allows more effective and faster cutting and grinding of metal and construction materials, grinding of welds, chamfering (roof tiles, metal prisms and bars, bricks, concrete, tiling). Construction and outer tool shell is dust-resistant and ensures long motor service life. The protective cover key-less adjustment. A slim, ergonomic body allows a comfortable tool grip and easy manipulation including hard-to-reach areas. Accidental restart protection in the case of a power outage.

Main features:

- 3 positions of handle adjustment
- Accidental start-up protection in the case of a power outage
- A Safety fuse

Technical specifications

| | |
|----------------------------|---------------------------|
| Order Number | XT105150 |
| Voltage | 230V/50Hz |
| Input power | 1200 W |
| Speed | 9,000 rpm |
| Cutting blade diameter | 150 mm |
| Spindle thread | M14 |
| Sound pressure level (LpA) | 89 dB |
| Sound power level (LwA) | 100 dB |
| Product includes | Key, handle, cover |
| Weight | 3.5 kg |





ANGLE GRINDER 2600 W 230 MM

Use of an Angle Grinder in combination with a proper attachment allows more effective and faster cutting and grinding of metal and construction materials, grinding of welds, chamfering (roof tiles, metal prisms and bars, bricks, concrete, tiling). Construction and outer tool shell is dust-resistant and ensures long motor service life. The protective cover key-less adjustment. A slim, ergonomic body allows a comfortable tool grip and easy manipulation including hard-to-reach areas. Accidental restart protection in the case of a power outage.

Main features:

- 2600W rotor to manage heavy load
- The soft-start function regulates the starting current and reduces kickback
- 3 positions of handle adjustment
- Accidental start-up protection in the case of a power outage



Technical specifications

| | |
|----------------------------|---------------------------|
| Order Number | XT105240 |
| Voltage | 230V/50Hz |
| Input power | 2600 W |
| Speed | 6,500 rpm |
| Cutting blade diameter | 230 mm |
| Soft-Start | YES |
| Spindle thread | M14 |
| Sound pressure level (LpA) | 99 dB |
| Sound power level (LwA) | 110 dB |
| Product includes | Key, handle, cover |
| Weight | 6 kg |





ANGLE GRINDER 1400 W 125 mm, SPEED CONTROL

The Angle Grinder with speed regulation is a universal tool due to various attachments for polishing, grinding, cutting, or milling. The attachments allow the use of a single grinder for operations concerning wood, metal, or construction materials.

Main features:

- Accidental start-up protection in case of a power outage
- Universal tool for polishing, grinding, cutting, or milling
- 6-level speed regulation
- 3 positions of handle adjustment
- A switch-lock

Technical specifications

| | |
|----------------------------|---|
| Order Number | XT105130 |
| Voltage | 230V/50Hz |
| Input power | 1400 W |
| Speed | 2,800-10,000 rpm |
| Speed regulation | YES (position 1 - 6) |
| Cutting blade diameter | 125 mm |
| Spindle thread | M14 |
| Sound pressure level (LpA) | 89 dB |
| Sound power level (LwA) | 93 dB |
| Product includes | Key, handle, cover, a pair of carbon brushes |
| Weight | 2.4 kg |



ALL ATTACHMENTS ONE ANGLE GRINDER



Thanks to compatible attachments, the angle grinder with speed control becomes a universal tool for polishing, grinding, cutting or milling. Attachments allow using a single grinder to work with wood, metal and building materials. Speed control allows you to use the optimal setting for a given type of material or work task.

Born for outstanding projects.

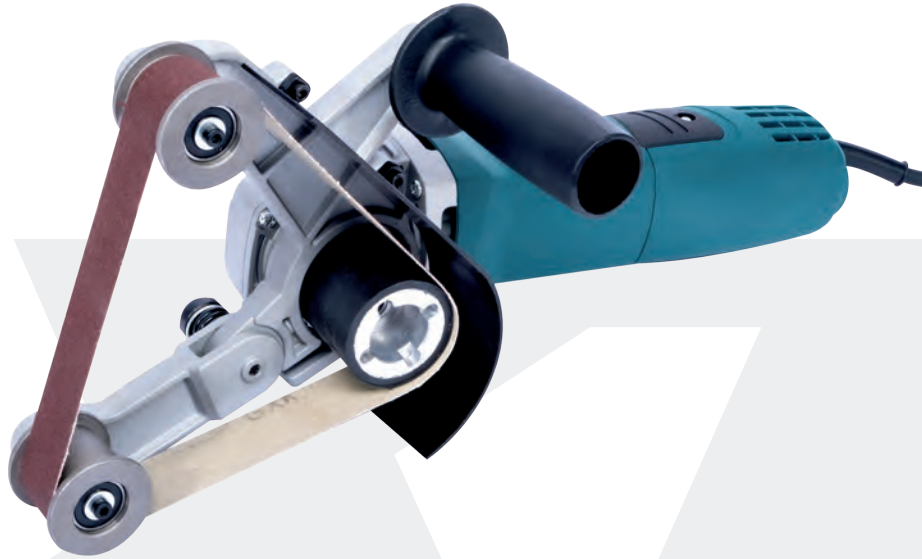

PIPE SANDER 1400 W 30x533 mm

Technical specifications

| | |
|----------------------------|-----------------------------|
| Order Number | XT105337 |
| Voltage | 230V/50Hz |
| Input power | 1400 W |
| Speed | 2,800-10,000 rpm |
| Speed regulation | YES (position 1 - 6) |
| Sanding belt dimensions | 30x533 mm |
| Spindle thread | M14 |
| Sound pressure level (LpA) | 89 dB |
| Sound power level (LwA) | 93 dB |
| Max. grinding diameter | 180 mm |
| Groove depth | 6-28 mm |
| Groove width | 25 mm |
| Weight | 3,4 kg |



PIPE SANDER ATTACHMENT 30x533 mm

Technical specifications

| | |
|-------------------------|--|
| Order Number | XT105305 |
| Recommended speed | 1-3 |
| Sanding belt dimensions | 30x533 mm |
| Spindle thread | M14 |
| Product includes | Reduction rings, handle, key, 3x sanding belt |
| Weight | 0.9 kg |





WHEEL BRUSH SANDER 1400 W, 125 mm

Technical specifications

| | |
|----------------------------|---------------------------------|
| Order Number | XT105345 |
| Voltage | 230V/50Hz |
| Input power | 1400 W |
| Speed | 2,800-10,000 rpm |
| Speed regulation | YES (position 1 - 6) |
| Wheel dimensions | 120x50 mm |
| Spindle thread | M14 |
| Sound pressure level (LpA) | 89 dB |
| Sound power level (LwA) | 93 dB |
| Product includes | Handle, wheel brush, key |
| Weight | 3 kg |



WHEEL BRUSH SANDER ATTACHMENT 125 mm



Technical specifications

| | |
|-------------------|---------------------------------|
| Order Number | XT105306 |
| Recommended speed | 1-3 |
| Wheel dimensions | 120x50 mm |
| Spindle thread | M14 |
| Product includes | Handle, wheel brush, key |
| Weight | 0.5 kg |





RANDOM ORBIT SANDER 1400 W, 150 mm

Technical specifications

| | |
|----------------------------|----------------------|
| Order Number | XT105325 |
| Voltage | 230V/50Hz |
| Input power | 1400 W |
| Speed | 2,800-10,000 rpm |
| Speed regulation | YES (position 1 - 6) |
| Cutting blade diameter | 150 mm |
| Spindle thread | M14 |
| Sound pressure level (LpA) | 89 dB |
| Sound power level (LwA) | 93 dB |
| Weight | 3 kg |



RANDOM ORBIT SANDER ATTACHMENT 150 mm

Technical specifications

| | |
|------------------------|--|
| Order Number | XT105307 |
| Recommended speed | 1-6 |
| Cutting blade diameter | 150 mm |
| Spindle thread | M14 |
| Product includes | Handle, reduction rings, 3x sanding pad (P80, 100, 120), key |
| Weight | 0.5 kg |





ANGLE GRINDER WITH SUCTION COVER 1400 W, 115/125 mm

Technical specifications

| | |
|----------------------------|--|
| Order Number | XT105140 |
| Voltage | 230V/50Hz |
| Input power | 1400 W |
| Speed | 2,800-10,000 rpm |
| Speed regulation | YES (position 1 - 6) |
| Cutting blade diameter | 115 / 125 mm |
| Spindle thread | M14 |
| Sound pressure level (LpA) | 89 dB |
| Sound power level (LwA) | 93 dB |
| Product includes | Handle, protective cover, reduction adapter, key, reduction rings |
| Weight | 3 kg |



SUCTION COVER ATTACHMENT 115/125 mm

Technical specifications

| | |
|------------------------|--|
| Order Number | XT105312 |
| Recommended speed | 4-6 |
| Cutting blade diameter | 115 / 125 mm |
| Spindle thread | M14 |
| Product includes | Key, handle, reduction rings, reduction adapter |
| Weight | 0.4 kg |





GROOVE MILLING GRINDER 1400 W, 125 mm

Technical specifications

| | |
|----------------------------|-------------------------------------|
| Order Number | XT105320 |
| Voltage | 230V/50Hz |
| Input power | 1400 W |
| Speed | 2,800-10,000 rpm |
| Speed regulation | YES (position 1 - 6) |
| Cutting blade diameter | 125 mm |
| Spindle thread | M14 |
| Sound pressure level (LpA) | 89 dB |
| Sound power level (LwA) | 93 dB |
| Product includes | Reduction rings, key, handle |
| Weight | 3.5 kg |



GROOVE MILLING ATTACHMENT 115/125 mm

Technical specifications

| | |
|------------------------|-------------------------------------|
| Order Number | XT105315 |
| Recommended speed | 4-6 |
| Cutting blade diameter | 125 mm |
| Spindle thread | M14 |
| Product includes | Handle, reduction rings, key |
| Weight | 1.1 kg |





BELT SANDER 1400 W 30x533/9x533 mm

Technical specifications

| | |
|----------------------------|--|
| Order Number | XT105342 |
| Voltage | 230V/50Hz |
| Input power | 1400 W |
| Speed | 2,800-10,000 rpm |
| Speed regulation | YES (position 1 - 6) |
| Sanding belt dimensions | 30x533 / 9x533 mm |
| Spindle thread | M14 |
| Sound pressure level (LpA) | 89 dB |
| Sound power level (LwA) | 93 dB |
| Product includes | Reduction rings, handle, key, 3x sanding belt 30x533, 3x sanding belt 9x533 mm |
| Weight | 3 kg |



BELT SANDER ATTACHMENT 30x533/9x533 mm



Technical specifications

| | |
|-------------------------|--|
| Order Number | XT105319 |
| Recommended speed | 1-3 |
| Sanding belt dimensions | 30x533 mm |
| Spindle thread | M14 |
| Product includes | 6x sanding belt, reduction rings, handle |
| Weight | 0.6 kg |





MULTI-TOOL 400 W

+ ACCESSORY KIT

The Oscillating Multi-tool Sander is designed for use in households and workshops. Various attachments allow the use for cutting, sanding, or paint and lacquer removal including hard-to-reach areas. A flat saw blade for splitting materials (wood, drywall, soft metals, etc.) can be fitted at various angles. Possibility to connect a dust extraction system. Speed regulation. Key-less tool replacement (locking mechanism).

Main features:

- 6-level speed regulation
- Key-less tool replacement (locking mechanism)
- Dust extraction system
- Great choice of attachments

Technical specifications

| | |
|----------------------------|---|
| Order Number | XT106200 |
| Voltage | 230V/50Hz |
| Input power | 400 W |
| Speed | 15,000-22,000 rpm |
| Speed regulation | YES (position 1 - 6) |
| Sound pressure level (LpA) | 84 dB |
| Sound power level (LwA) | 98 dB |
| Product includes | 3x sandpaper (P40, 60, 80), 1x semi-round, 1x flat saw blade |
| Weight | 1.6 kg |





PIPE SANDER 1300 W

A pipe sander is used for grinding, polishing or cleaning materials. The advantage is a wide angle, which enables the grinding of small parts. Clamping the attachment is very easy and fast. Maximum grinding angle and machining of large objects with a diameter of up to 180 mm.

Main features:

Speed regulation

Large sanding angle (270°) for effective operation



Technical specifications

| | |
|----------------------------|---|
| Order Number | XT105340 |
| Voltage | 230V/50Hz |
| Input power | 1300 W |
| Speed | 1,100-3,200 rpm |
| Speed regulation | YES (position 1 - 6) |
| Sanding belt dimensions | 40x760 mm |
| Spindle thread | M14 |
| Sound pressure level (LpA) | 94.5 dB |
| Sound power level (LwA) | 105 dB |
| Product includes | 3x sanding belt (P120, P100, P80), handle, a pair of carbon brushes, key |
| Weight | 3.8 kg |





BELT SANDER 1010 W

The Belt Sander is used for sanding wood (beams, laths, boards), metal (corrosion removal, metal surfaces). It can be used for area sanding of lacquered, painted, and sealed surfaces. It benefits from the possibility of sandpaper centering. Fast and easy sandpaper replacement by loosening the lock and handle position adjustment using the locking mechanism. Speed regulation.

Main features:

- Easy carbon brush replacement without removing the body cover
- The sand paper centering
- Handle position adjustment locking mechanism
- Speed regulation
- Tiltable front cover for hard-to-reach areas

Technical specifications

| | |
|----------------------------|-----------------------------|
| Order Number | XT106310 |
| Voltage | 230V/50Hz |
| Input power | 1010 W |
| Speed | 120-380 rpm |
| Speed regulation | YES (position 1 - 6) |
| Sanding belt dimensions | 75x533 mm |
| Sound pressure level (LpA) | 90 dB |
| Sound power level (LwA) | 101 dB |
| Product includes | Dust bag |
| Weight | 3.5 kg |

WHEEL BRUSH SANDER 1300 W, 120x100 mm

Optimal sander use due to small handle circumference and its exceptional ergonomic position. The Wheel Brush Sander is used for sanding, polishing, structuring, dulling, and satin finishing. Ideal for work with wood, steel, stainless-steel, non-ferrous metals, and plastics.

Main features:

- Continuous speed regulation
- Excellent grip due to the comfortable handle

Technical specifications

| | |
|----------------------------|---|
| Order Number | XT105350 |
| Voltage | 230V/50Hz |
| Input power | 1300 W |
| Speed | 900-3,200 rpm |
| Speed regulation | YES (position 1 - 6) |
| Wheel dimensions | 120x100 mm |
| Spindle thread | M14 |
| Sound pressure level (LpA) | 88 dB |
| Sound power level (LwA) | 99 dB |
| Product includes | Allen key, protective covert, adapter, handle |
| Weight | 2.8 kg |



XT105350K





RANDOM ORBIT POLISHER 600 W, 150 mm

The Random Orbit Polisher is designed especially for polishing, water-free car paint conservation and treatment, and retouching minor defects in car lacquer layer (e.g. Removing deeper scratches, repainting, asphalt and insect impurities, grinding of a micro-layer of weathered lacquer for original colour revitalisation, grinding a treating corroded areas, removing of micro scratches after water cleaning, holograms, etc.) with the use of suitable foam wheels and respective pasta or polisher type.

Main features:

The tool shape allows easy manipulation
Designed for fine grinding and polishing
6-level speed regulation

Technical specifications

| | |
|----------------------------|---|
| Order Number | XT105300 |
| Voltage | 230V/50Hz |
| Input power | 600 W |
| Speed | 1,500-3,700 / 4,800-6,800 rpm |
| Cutting blade diameter | 150 mm |
| Excentricity | 8 mm |
| Sound pressure level (LpA) | 80 dB |
| Sound power level (LwA) | 91 dB |
| Product includes | Polishing wheel, handle, drive pad |
| Weight | 2.2 kg |





ORBITAL SANDER DELTA

200 W, 150x100 mm

The oscillation sander is a tool used for sanding wooden materials, metals, but also for grinding damaged areas of surface treatment and hard-to-reach areas.

Main features:

- Effective dust extraction
- LED work light
- Comfortable one-hand handle



Technical specifications

| | |
|----------------------------|----------------------|
| Order Number | XT106235 |
| Voltage | 230V/50Hz |
| Input power | 200 W |
| Speed | 12,500 rpm |
| Sanding area | 150x100 mm |
| Power cord length | 2 m |
| Sound pressure level (LpA) | 77.7 dB |
| Sound power level (LwA) | 88.7 dB |
| Product includes | Sandpaper P80 |
| Weight | 1.3 kg |



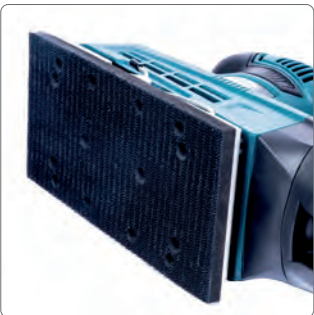

OSCILLATION SANDER 240 W

Oscillation Sander offers a simple velcro-system sandpaper replacement. It consists of Aluminum base and sandpaper clamp. Efficient dust collection system.

Main features:

- Effective dust extraction
- Easy sand paper replacement due to Velcro system
- Ergonomically designed rubber handle

Technical specifications

| | |
|----------------------------|-----------------------------|
| Order Number | XT106245 |
| Voltage | 230V/50Hz |
| Input power | 240 W |
| Speed | 6,000-12,000 rpm |
| Speed regulation | YES (position 1 - 6) |
| Sanding area | 90x182 mm |
| Power cord length | 2 m |
| Sound pressure level (LpA) | 79.1 dB |
| Sound power level (LwA) | 90.1 dB |
| Product includes | Sandpaper P80 |
| Weight | 1.5 kg |



RANDOM ORBIT SANDER

450 W, 125 mm

Random Orbit Sander with ergonomic construction is perfect for sanding or polishing various materials, paint, and lacquer. The handle provides comfortable grip in every work position. Main benefits: Effective dust collection system reduces dust-related health risks when manipulating the tool, top grip for comfortable handling, speed regulation.

Main features:

- Effective dust extraction
- Comfortable top grip



Technical specifications

| | |
|----------------------------|-----------------------------|
| Order Number | XT106382 |
| Voltage | 230V/50Hz |
| Input power | 450 W |
| Speed | 6,000-13,000 rpm |
| Speed regulation | YES (position 1 - 6) |
| Cutting blade diameter | 125 mm |
| Sound pressure level (LpA) | 81.6 dB |
| Sound power level (LwA) | 92.6 dB |
| Product includes | Sandpaper P80 |
| Weight | 1.8 kg |





DRYWALL SANDER 710 W 225 mm

The Drywall Sander allows sanding drywall surfaces and boards, lacquered surfaces, and plasters. It benefits from a retractable shaft that allows an extension of the handle and makes the operation easier and more convenient. Rear-positioned motor for proper balance during operation.

Main features:

- Rear-positioned motor for proper balance during operation
- Flexible hose for dust extraction
- LED work light
- Speed regulation adjustment

Technical specifications

| | |
|----------------------------|---|
| Order Number | XT106322 |
| Voltage | 230V/50Hz |
| Input power | 710 W |
| Speed | 1,000-2,000 rpm |
| Speed regulation | YES (position 1 - 2) |
| Cutting blade diameter | 225 mm |
| Hose length | 2 m |
| Sound pressure level (LpA) | 95 dB |
| Sound power level (LwA) | 106 dB |
| Product includes | Key, a pair of carbon brushes, dust hose, 6x sandpaper (2xP150, 2xP180, 2xP240), 2x vacuum cleaner adapter |
| Weight | 4.6 kg |





STRAIGHT GRINDER 170 W

Small straight face grinder for fine grinding, sanding or polishing of metal, wood, plastics or glass. It is an ideal tool for DIYers or modelers.

Main features:

- Ergonomic shape for safe and comfortable work
- Speed control for versatile use
- Long, flexible spindle



Technical specifications

| | |
|----------------------------|--|
| Order Number | XT107060 |
| Voltage | 230V/50Hz |
| Input power | 170 W |
| Speed | 10,000-35,000 rpm |
| Speed regulation | YES (position 1 - 6) |
| Collet | 1.8 - 3.2 mm |
| Sound pressure level (LpA) | 75.7 dB |
| Sound power level (LwA) | 86.7 dB |
| Product includes | 40pcs grinding bit set, flexible spindle, box |
| Weight | 0.9 kg |



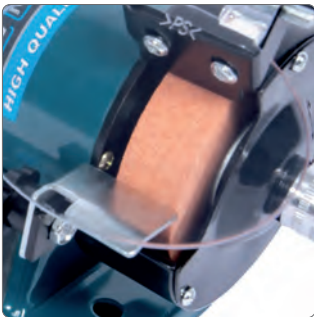

DUAL WHEEL BENCH GRINDER 150 W, STRAIGHT GRINDER

75 mm

The Dual Bench Grinder with the possibility of using abrasive bodies with a flexible shaft is ideal for hard-to-reach areas. A great tool for modelers and DIYs. Perfect for fine grinding, polishing, and metal, plastics, wood, or glass processing.

Main features:

- Speed regulation
- Flexible spindle for clamping abrasive bits

Technical specifications

| | |
|----------------------------|-------------------------|
| Order Number | XT107100 |
| Voltage | 230V/50Hz |
| Input power | 150 W |
| Speed | 0-10,000 rpm |
| Cutting blade dimensions | 75x20x10 mm |
| Collet | 1.8 - 3.2 mm |
| Sound pressure level (LpA) | 75 dB |
| Sound power level (LwA) | 88 dB |
| Product includes | Flexible spindle |
| Weight | 2.7 kg |



DUAL SLOW WHEEL BENCH GRINDER 250 W

150/200 mm

The Dual Slow Wheel Grinder is designed for blade, scissors, and chisel sharpening. The second wheel with a backrest for grinding. Stable metal body and a water tank with rubber outlet

Main features:

- Spark protection
- Water container with the drain
- Water-cooled low-speed wheel
- Dustproof switch

Technical specifications

| | |
|----------------------------|--|
| Order Number | XT107175 |
| Voltage | 230V/50Hz |
| Input power | 250 W |
| Speed | 134 / 2,980 rpm |
| Cutting blade dimensions | 200x40x20 mm (big) 150x15x12.7 mm (small) |
| Sound pressure level (LpA) | 83.5 dB |
| Sound power level (LwA) | 96.5 dB |
| Weight | 8.5 kg |

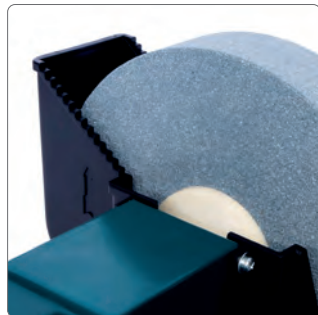



DUAL WHEEL BENCH GRINDER WITH LAMP 520 W

200 mm

A powerful Dual Wheel Grinder for heavy-duty metal machining and deburring. Its solid construction eliminates the vibration and eccentricity of the wheel. Rough and fine wheel for perfect grinding, sharpening, or edge smoothing.

Main features:

- LED work light
- Wheel alignment
- A powerful motor for heavy-duty machining and deburring
- Dustproof switch



Technical specifications

| | |
|----------------------------|---------------------|
| Order Number | XT107200 |
| Voltage | 230V/50Hz |
| Input power | 520 W |
| Speed | 2,950 rpm |
| Cutting blade dimensions | 200x25x16 mm |
| Spindle thread | M16 |
| Sound pressure level (LpA) | 82.7 dB |
| Sound power level (LwA) | 95.7 dB |
| LED light | 3 W |
| Weight | 18 kg |

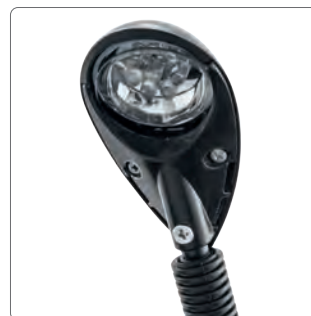



CHAINSAW SHARPENER 85 W

Designed for chainsaw sharpening. The steel clamp is controlled by a handle lever that speeds up the operation.

Main features:

- Clamp control on the handle
- Precision grinding

Technical specifications

| | |
|----------------------------|------------------------|
| Order Number | XT108802 |
| Voltage | 230V/50Hz |
| Input power | 85 W |
| Speed | 4,800 rpm |
| Cutting blade dimensions | 108x22,2x3.2 mm |
| Sound pressure level (LpA) | 83 dB |
| Sound power level (LwA) | 96 dB |
| For saw blades diameter | 90 - 400 mm |
| Weight | 2.8 kg |





SAW BLADE SHARPENER 110 W

Suitable for precise saw blade sharpening. Very durable and reliable grinder. An easy-to-adjust grinding angle ensures an accurate operation.

Main features:

- Adjustable angle for precise grinding
- Quick and easy clamping

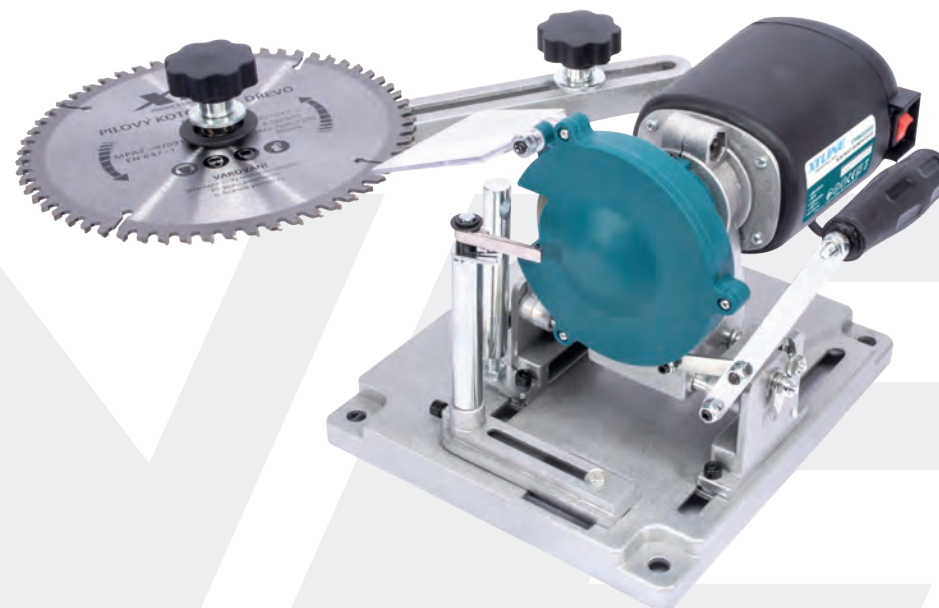

Technical specifications

| | |
|-----------------------------|------------------|
| Order Number | XT108803 |
| Voltage | 230V/50Hz |
| Input power | 110 W |
| Speed | 5,300 rpm |
| Cutting blade diameter | 100 mm |
| Sound pressure level (LpA) | 89 dB |
| Sound power level (LwA) | 102 dB |
| Grinding angle of drill bit | 130° |
| Weight | 5.4 kg |



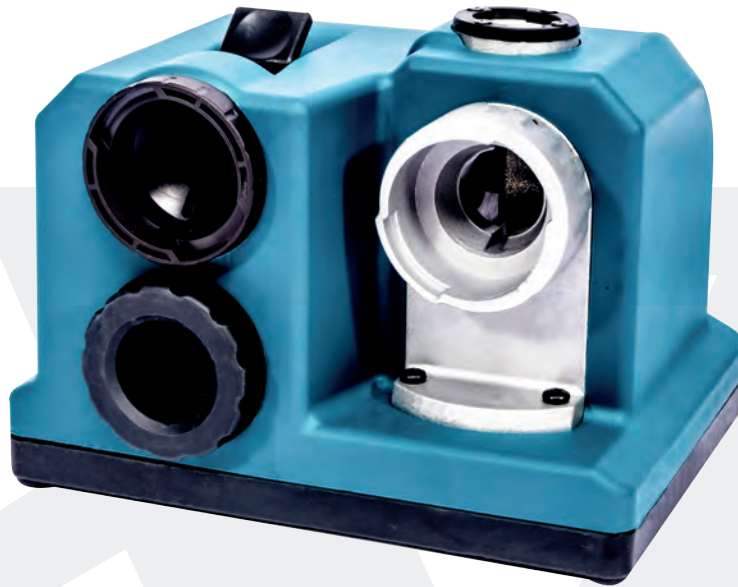

DRILL BIT SHARPENER 80 W

Designed for grinding or shaping of drill bit tips. Universal fitting chuck for easy bit adjustment and simple sharpening operation.

Main features:

- Easy exchange of grinding rings
- Easily replaceable diamond discs
- Simple operation

Technical specifications

| | |
|----------------------------|-------------------|
| Order Number | XT108808 |
| Voltage | 230V/50Hz |
| Input power | 80 W |
| Speed | 4,800 rpm |
| Drill bit diameter | 3-13 mm |
| Drill bit length | min. 60 mm |
| Sound pressure level (LpA) | 96 dB |
| Sound power level (LwA) | 102 dB |
| Weight | 2.9 kg |

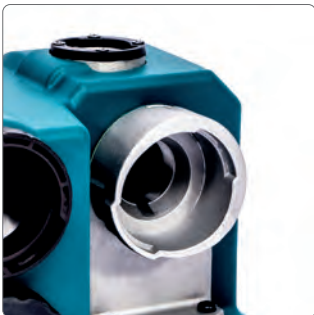



Born for outstanding projects.



Model: XT106395



ROUTER 1200 W

A powerful Router with a very compact design and simple controls is designed for cutting profiles, edges, and holes based on the shape of the router bit. Compatible with router bit shanks with a diameter of 8/12 mm.

Main features:

- Dust extraction system
- Easy collet replacement
- Speed regulation
- Comfortable grip
- Milling depth adjustment
- Massive aluminium base

Technical specifications

| | |
|----------------------------|--|
| Order Number | XT106395 |
| Voltage | 230V/50Hz |
| Input power | 1200 W |
| Speed | 16,000-30,000 rpm |
| Speed regulation | YES (position 1 - 6) |
| Collet | 8/12 mm |
| Sound pressure level (LpA) | 87.9 dB |
| Sound power level (LwA) | 93.5 dB |
| Product includes | Collet 8/12 mm, ruller, key, a pair of carbon brushes, copy ring, attachment for extraction |
| Weight | 4.5 kg |





MULTIFUNCTIONAL TRIM ROUTER 710 W

The Trim Router is designed for cutting profiles, edges, and various wood holes based on the shape of the router bit. The tool is compatible with router bit shanks with a diameter of 6 / 8mm. The Trimmer is equipped with the plunge base with the depth-stop and allows a precise adjustment in the range of tenths of a millimeter.

Main features:

- Easy collet replacement
- Speed regulation
- Dust extraction system
- Practical textile bag

Technical specifications

| | |
|----------------------------|---|
| Order Number | XT106400 |
| Voltage | 230V/50Hz |
| Input power | 710 W |
| Speed | 13,000-33,000 otmin |
| Speed regulation | YES (position 1 - 6) |
| Collet | 6/8 mm |
| Power cord length | 2,7 m |
| Sound pressure level (LpA) | 92.15 dB |
| Sound power level (LwA) | 103.15 dB |
| Product includes | 3x different bases (plunge, one-hand, pre-set), suction adapters, alignment guide, parallel guide, copy ring, key, a pair of carbon brushes, bag |
| Weight | 1.8 kg |





CIRCULAR SAW 1300 W 160 mm

The Circular Saw is designed for cutting wood and similar board materials. It is also suitable for cutting plastics and Aluminum profiles.

Main features:

- Depth-stop and angle adjustment
- Metal cover
- Aluminum base for cutting stability
- Parallel guide

Technical specifications

| | |
|------------------------------|--|
| Order Number | XT106160 |
| Voltage | 230V/50Hz |
| Input power | 1300 W |
| Speed | 4,700 rpm |
| Cutting capacity at 90°/ 45° | 55 / 35 mm |
| Miter cut | 0°-45° |
| Cutting blade diameter | 160 mm |
| Disc clamping | 16 mm |
| Sound pressure level (LpA) | 97 dB |
| Sound power level (LwA) | 108 dB |
| Product includes | Guide, key, a pair of carbon brushes, saw blade |
| Weight | 3.5 kg |

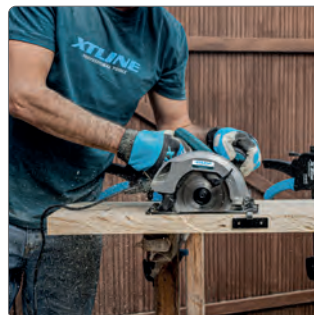



CIRCULAR SAW 1380 W 185 mm

The Circular Saw is designed for cutting wood and similar board materials. It is also suitable for cutting plastics and Aluminum profiles.

Main features:

- Depth-stop and angle adjustment
- Metal cover
- Aluminum base for cutting stability
- Parallel guide



Technical specifications

| | |
|------------------------------|--|
| Order Number | XT106187 |
| Voltage | 230V/50Hz |
| Input power | 1380 W |
| Speed | 5,300 rpm |
| Cutting capacity at 90°/ 45° | 62 / 46 mm |
| Miter cut | 0°-45° |
| Cutting blade diameter | 185 mm |
| Disc clamping | 30 mm |
| Sound pressure level (LpA) | 92.4 dB |
| Sound power level (LwA) | 103.4 dB |
| Product includes | Guide, key, a pair of carbon brushes, saw blade |
| Weight | 4.1 kg |





CIRCULAR SAW 1400 W 190 mm

The Circular Saw is designed for cutting wood and similar board materials. It is also suitable for cutting plastics and Aluminum profiles.

Main features:

- Depth-stop and angle adjustment
- Metal cover
- Aluminum base for cutting stability
- Parallel guide

Technical specifications

| | |
|------------------------------|--|
| Order Number | XT106190 |
| Voltage | 230V/50Hz |
| Input power | 1400 W |
| Speed | 4,700 rpm |
| Cutting capacity at 90°/ 45° | 63 / 44 mm |
| Miter cut | 0°-45° |
| Cutting blade diameter | 190 mm |
| Soft-Start | YES |
| Disc clamping | 20 mm |
| Sound pressure level (LpA) | 97 dB |
| Sound power level (LwA) | 108 dB |
| Product includes | Guide, key, a pair of carbon brushes, saw blade |
| Weight | 4.1 kg |





PLANER 750 W

The Planer is designed for woodworking. The cutting depth adjustment up to 3 mm based on the type of material. An 18mm cutting depth guarantees universality when cutting grooves and edges.

Main features:

- Softened handle for comfortable operation
- 13-position depth adjustment for precise material removal
- Two-sided dust extraction system
- Accidental start-up switch protection
- A practical stand allows workpiece planing in a static position
- Foot for safe storage of the planer

Technical specifications

| | |
|----------------------------|--|
| Order Number | XT106372 |
| Voltage | 230V/50Hz |
| Input power | 750 W |
| Speed | 17,000 rpm |
| Blade dimensions | 82x3 mm |
| Adjustable cutting height | 0-3 mm |
| Plane width | 82 mm |
| V-groove width | 8 mm |
| Chamfer groove depth | 0-18 mm |
| Sound pressure level (LpA) | 84 dB |
| Sound power level (LwA) | 95 dB |
| Product includes | Blade protection, base stand, base, guide |
| Weight | 3 kg |





RECIPROCATING SAW 650 W

The Reciprocating Saw is used for cutting wood, pipes, profiles, etc. Key-less saw blade replacement.

Main features:

- Saw blade quick-release system
- 5-level speed regulation according to the material type
- Excellent ergonomics and grip

Technical specifications

| | |
|----------------------------|---|
| Order Number | XT106390 |
| Voltage | 230V/50Hz |
| Input power | 650 W |
| Speed | 800-3,000 rpm |
| Max. cutting capacity | metal 10 mm, wood 115 mm, aluminum 20 mm |
| Sound pressure level (LpA) | 87 dB |
| Sound power level (LwA) | 98 dB |
| Product includes | saw blade for wood / metal, a pair of carbon brushes |
| Weight | 2.7 kg |



JIG SAW 600 W

The Jig Saw for cutting wood, chipboard, and metal. The possibility of a pendulum action adjustment and adaptation to the speed and method of cutting. Fast and key-less saw blade replacement.

Main features:

- Saw blade quick-release system
- Excellent ergonomic and grip
- Dust extraction system
- Pendulum action
- Angle cutting
- Coated base to protect the workpiece

Technical specifications

| | |
|----------------------------|---|
| Order Number | XT106360 |
| Voltage | 230V/50Hz |
| Input power | 600 W |
| Speed | 500-2,500 rpm |
| Speed regulation | YES (position 1 - 6) |
| Max. cutting capacity | metal 10 mm, wood 130 mm, aluminum 30 mm |
| Miter cut | 0°-45° |
| Pendulum levels | 3 |
| Clamping | T-type |
| Sound pressure level (LpA) | 90 dB |
| Sound power level (LwA) | 101 dB |
| Product includes | 2x saw blade, a pair of carbon brushes, guide, extraction adapter, box |
| Weight | 3 kg |





JIG SAW 550 W

The Jig Saw for cutting wood, chipboard, and metal. The possibility of a pendulum action adjustment and adaptation to the speed and method of cutting. Fast and key-less saw blade replacement.

Main features:

- Saw blade quick-release system
- 6-level speed regulation according to the material type
- Pendulum action
- Excellent ergonomics and grip
- Dust extraction system

Technical specifications

| | |
|----------------------------|---|
| Order Number | XT106365 |
| Voltage | 230V/50Hz |
| Input power | 550 W |
| Speed | 800-2,600 rpm |
| Speed regulation | YES (position 1 - 6) |
| Max. cutting capacity | metal 6 mm, wood 65 mm, aluminum 12 mm |
| Miter cut | 0°-45° |
| Pendulum levels | 3 |
| Clamping | T-type |
| Sound pressure level (LpA) | 80.9 dB |
| Sound power level (LwA) | 91.9 dB |
| Product includes | 2x saw blade, a pair of carbon brushes, key, guide, extraction adapter |
| Weight | 2.1 kg |



JIG SAW 750 W

The Jig Saw for cutting wood, chipboard, and metal. The possibility of a pendulum action adjustment and adaptation to the speed and method of cutting. Fast and key-less saw blade replacement.

Main features:

- Saw blade quick-release system
- 6-level speed regulation according to the material type
- Pendulum action
- Palm grip ergonomics
- Dust extraction system
- Angle cutting
- Coated base to protect the workpiece



Technical specifications

| | |
|----------------------------|---|
| Order Number | XT106368 |
| Voltage | 230V/50Hz |
| Input power | 750 W |
| Speed | 600-2,900 rpm |
| Speed regulation | YES (position 1 - 6) |
| Max. cutting capacity | metal 10 mm, wood 120 mm |
| Miter cut | 0°-45° |
| Pendulum levels | 3 |
| Clamping | T-type |
| Sound pressure level (LpA) | 88.6 dB |
| Sound power level (LwA) | 99.6 dB |
| Product includes | 2x saw blade, ruler, a pair of carbons, extraction adapter |
| Weight | 2.8 kg |





SLIDING MITER SAW WITH LASER 1700 W, 210 mm

The Miter Saw is suitable for cutting wood, tiling boards, plastics, and non-ferrous metals. A practical cutting line marked by the laser feature. Very compact design for easy transport and storage. The saw offers smooth cutting operation due to a powerful high-speed motor. Extra work safety and comfort are provided by wide support handles.

Main features:

- Low weight
- Compact storage size
- Practical handle for transport

Technical specifications

| | |
|-------------------------------|---|
| Order Number | XT106210 |
| Voltage | 230V/50Hz |
| Input power | 1700 W |
| Speed | 4,500 rpm |
| Cutting capacity at 90°/ 90° | 230x60 mm |
| Cutting capacity at 90°/ 45° | 230x35 mm |
| Cutting capacity at 45°/ 90° | 155x60 mm |
| Cutting capacity at 45° / 45° | 155x35 mm |
| Miter cut | 0°-45° |
| Cutting blade diameter | 210 mm |
| Disc clamping | 30 mm |
| Sound pressure level (LpA) | 105.9 dB |
| Sound power level (LwA) | 118.9 dB |
| Product includes | Saw blade, key, dust bag, table extension, clamp, a pair of carbon brushes |
| Weight | 9.5 kg |



SLIDING MITER SAW WITH LASER 2000 W, 255 mm

The Sliding Miter Saw is suitable for cutting wood, tiling boards, plastics, and non-ferrous metals. A practical cutting line marked by the laser feature. Very compact design for easy transport and storage. The saw offers smooth cutting operation due to a powerful high-speed motor. Possibility to position the machine right next to the wall.

Main features:

- Possibility to work close to the wall
- Compact storage size

Technical specifications

| | |
|-------------------------------|---|
| Order Number | XT106255 |
| Voltage | 230V/50Hz |
| Input power | 2000 W |
| Speed | 4,500 rpm |
| Cutting capacity at 90° / 90° | 305x56 mm |
| Cutting capacity at 90° / 45° | 305x55 mm |
| Cutting capacity at 45° / 90° | 210x56 mm |
| Cutting capacity at 45° / 45° | 210x55 mm |
| Miter cut | 0°-45° |
| Cutting blade diameter | 255 mm |
| Disc clamping | 30 mm |
| Sound pressure level (LpA) | 99 dB |
| Sound power level (LwA) | 110 dB |
| Product includes | Saw blade, key, dust bag, a pair of carbon brushes |
| Weight | 15.5 kg |





SLIDING MITER SAW WITH LASER 2200 W, 255 mm

The Sliding Miter Saw is suitable for cutting wood, tiling boards, plastics, and non-ferrous metals. The saw offers smooth cutting operation due to a powerful high-speed motor. Extra work safety and comfort are provided by wide support handles.

Main features:

- Soft-start function
- Powerful motor

Technical specifications

| | |
|-------------------------------|--|
| Order Number | XT106260 |
| Voltage | 230V/50Hz |
| Input power | 2200 W |
| Speed | 5,000 rpm |
| Cutting capacity at 90°/ 90° | 305x70 mm |
| Cutting capacity at 90°/ 45° | 200x70 mm |
| Cutting capacity at 45°/ 90° | 305x43 mm |
| Cutting capacity at 45° / 45° | 200x43 mm |
| Miter cut | 0°-45° |
| Cutting blade diameter | 255 mm |
| Soft-Start | YES |
| Disc clamping | 30 mm |
| Sound pressure level (LpA) | 92 dB |
| Sound power level (LwA) | 105 dB |
| Product includes | Saw blade, key, dust bag, table extension, clamp, a pair of carbon brushes, batteries for laser |
| Weight | 16.6 kg |





SLIDING MITER SAW WITH LASER 2000 W, 305 mm

The Sliding Miter Saw is suitable for cutting wood, tiling boards, plastics, and non-ferrous metals. Unlike direct drive saw types, the belt drive design is much more gentle to the motor itself.

Main features:

- Belt drive
- Large and robust miter table

Technical specifications

| | |
|-------------------------------|---|
| Order Number | XT106305 |
| Voltage | 230V/50Hz |
| Input power | 2000 W |
| Speed | 4,500 rpm |
| Cutting capacity at 90° / 90° | 340x120 mm |
| Cutting capacity at 90° / 45° | 340x48 mm (left) / 340x40 mm (right) |
| Cutting capacity at 45° / 90° | 235x120 mm |
| Cutting capacity at 45° / 45° | 235x48 mm (left) / 235x40 mm (right) |
| Miter cut | -45° / +45° |
| Cutting blade diameter | 305 mm |
| Disc clamping | 30 mm |
| Sound pressure level (LpA) | 92 dB |
| Sound power level (LwA) | 105 dB |
| Product includes | Saw blade, key, dust bag, table extension, clamp, a pair of carbon brushes |
| Weight | 17 kg |





POLYFUSION WELDER 800 W

The Polyfusion blade welder for welding of pipes of all kinds of thermoplastic materials with a diameter of up to 63mm. The attachments are equipped with a non-stick Teflon surface. The possible temperature adjustment of 0 to 300°C within 15 minutes. Indication of reaching the optimal work temperature and On/Off status.

Main features:

- Smooth temperature setting 0-300°C
- Wide range of attachments

Technical specifications

| | |
|------------------|----------------------------------|
| Order Number | XT101001 |
| Voltage | 230V/50Hz |
| Input power | 800 W |
| Temperature | 0-300 °C |
| Preheat time | < 15 min. |
| Attachments | 20, 25, 32, 40, 50, 63 mm |
| Other features | Temperature regulation |
| Product includes | Attachments, stand, box |
| Weight | 3.4 kg |



POLYFUSION WELDER 800 W

The Polyfusion blade welder for welding of pipes of all kinds of thermoplastic materials with a diameter of up to 32mm. The attachments are equipped with a non-stick Teflon surface. The possible temperature adjustment of 0 to 300°C within 15 minutes. Indication of reaching the optimal work temperature and On/Off status.

Main features:

- Smooth temperature regulation 0-300°C.
- Accessories of attachments



Technical specifications

| | |
|---------------------|-------------------|
| Order Number | XT103001 |
| Voltage | 230V/50Hz |
| Input power | 800 W |
| Temperature | 0-300 °C |
| Preheat time | < 15 min. |
| Attachments | 16, 20, 25, 32 mm |
| Product includes | Adapters, box |
| Weight | 3.4 kg |





INVERTER WELDER 160 A

The Inverter Welder is suitable for use either at home or in production. It is equipped with an LCD display that makes the operation more convenient. Its best features are continuous regulation and a high maximum current of 160A.

Main features:

- The low weight makes the tool transport easier
- Automatic overvoltage, undervoltage, overheating protection
- Suitable for basic electrodes

Technical specifications

| | |
|----------------------------|--|
| Order Number | XT103160 |
| Voltage | 230V/50Hz |
| Input power | 5300 W |
| Welding current | 10 - 160 A |
| Welding electrode diameter | 1.6 - 4 mm |
| Max. current | 160 A |
| Load MMA (40°C) | 71 A - 100% / 92 A - 60% / 160 A - 20% |
| Product includes | Electrode holder, welding cables, hammer brush, welding shield |
| Cable length | 1,2 + 2 m |
| Weight | 4 kg |





HEAT GUNS WITH REGULATION 2000 W

The Heat Gun is used for old paint and lacquer removal, shaping, and soldering using hot air. Various attachments for effective and easy manipulation are included.

Main features:

- Temperature adjustment
- A large number of nozzle accessories for welding + box

Technical specifications

| | |
|---------------------|---------------------------------|
| Order Number | XT106220 |
| Voltage | 230V/50Hz |
| Input power | 2000 W |
| Air temperature | 50°C / 50°C-450°C / 450°C-600°C |
| Air flow | 500 / 250 / 500 l/min |
| Product includes | 4x nozzle, scraper, box |
| Weight | 1 kg |
| Order Number | XT106230 |
| Voltage | 230V/50Hz |
| Input power | 2000 W |
| Air temperature | 50-650°C |
| Air flow | 250 - 500 l/min |
| Product includes | 4x nozzle, scraper, box |
| Weight | 1 kg |



XT106220



XT106230





OIL AIR COMPRESSOR 1500 W, 24 L

The Oil Air Compressor for compressed air production with the maximum pressure of 8 bar to supply pneumatic tools, spray guns, inflating of tires, etc. A versatile helper in the home and in the workshop.

Main features:

- 24 l tank
- Suitable for pneumatic tools
- Larger piston size for increased engine life
- Pressure regulation
- Thermal fuse

Technical specifications

| | |
|----------------------------|-----------|
| Order Number | XT2002 |
| Voltage | 230V/50Hz |
| Input power | 1500 W |
| Speed | 2,850 rpm |
| Tank volume | 24 l |
| Max. pressure | 8 bar |
| Approximate suction power | 187 l/min |
| Approximate filling power | 125 l/min |
| Sound pressure level (LpA) | 69.6 dB |
| Sound power level (LwA) | 89.6 dB |
| Weight | 23 kg |



OIL AIR COMPRESSOR 2200 W, 50 L

The Dual Valve Oil Air Compressor for compressed air production with the maximum pressure of 8 bar to supply pneumatic tools, spray guns, inflating of tires, etc. The oil-lubricated pump extends the service life even when frequently used. Two valves ensure a higher performance. The 50L volume provides a high liter performance.

Main features:

- Two pistons ensure a higher performance
- 50L tank provides high liter performance
- Pressure regulation
- Thermal fuse

Technical specifications

| | |
|----------------------------|------------------|
| Order Number | XT2004 |
| Voltage | 230V/50Hz |
| Input power | 2200 W |
| Speed | 2,850 rpm |
| Tank volume | 50 l |
| Max. pressure | 8 bar |
| Approximate suction power | 250 l/min |
| Approximate filling power | 162 l/min |
| Sound pressure level (LpA) | 69.6 dB |
| Sound power level (LwA) | 89.6 dB |
| Weight | 39 kg |





OIL-FREE AIR COMPRESSOR 1100 W

The Oil-free Air Compressor is suitable for inflating bicycle tires, car tires, air mattresses and toys, sports equipment, and beach accessories, such as balls, and boats. The machine is equipped with a three-meter, quick-release air hose.

Main features:

- Integrated accessory compartment
- Easy operation and handling

Technical specifications

| | |
|----------------------------|---------------------------------------|
| Order Number | XT2011 |
| Voltage | 230V/50Hz |
| Input power | 1100 W |
| Speed | 3,550 rpm |
| Max. pressure | 8 bar |
| Approximate filling power | 180 l/min |
| Sound pressure level (LpA) | 75 dB |
| Sound power level (LwA) | 97 dB |
| Product includes | Pressure gauge, adapters, attachments |
| Weight | 6 kg |





OIL-FREE AIR COMPRESSOR 900 W, 6 L

The Oil-free Air Compressor is very quiet, light and easy to transport. The Compressor is designed for service works (blowing of computer impurities, electric wiring), housework (inflating of balls, tires, stapling, spraying).

Main features:

- Low vibration
- Low noise level
- Maintenance-free operation
- Faster performance
- Pressure regulation



Technical specifications

| | |
|---------------------------|------------------|
| Order Number | XT2008 |
| Voltage | 230V/50Hz |
| Input power | 900 W |
| Speed | 2,800 rpm |
| Tank volume | 6 l |
| Max. pressure | 8 bar |
| Approximate filling power | 70 l/min |
| Power cord length | 1 m |
| Sound power level (LwA) | 70 dB |
| Weight | 12.6 kg |





INDUSTRIAL VACUUM CLEANER FOR DRY AND WET OPERATION 1400 W

+ ACCESSORY KIT

The Vacuum Cleaner is designed for vacuuming rough impurities in workshops, fine dust in households, or water in cellars. A flexible operation in hard-to-reach areas guaranteed.

Main features:

- The product includes a large number of accessories
- Possibility of the dry and wet vacuuming
- Possibility of extracting dust from power tools
- Low weight

Technical specifications

| | |
|---------------------------|---|
| Order Number | XT102819 |
| Voltage | 230V/50Hz |
| Input power | 1400 W |
| Vessel volume | 20 l |
| Hose length | 3 m |
| Approximate suction power | 58 l/s |
| Operation mode | dry / wet |
| Power cord length | 3 m |
| Sound power level (LwA) | 87 dB |
| Product includes | Floor tube, paper bag, slot nozzle, adapter, hepa filter, soft sponge filter, wheels (4pcs), Telescopic metal tube |
| Hose clamping hole | 56 mm |
| Weight | 4 kg |



INDUSTRIAL VACUUM CLEANER FOR DRY AND WET OPERATION 1600 W

+ ACCESSORY KIT

The Vacuum Cleaner is designed for wet and dry vacuuming of rough impurities in workshops, fine dust in households, or water in cellars. A flexible operation in hard-to-reach areas guaranteed. It is also fairly mobile due to a pair of universal wheels on the front and back.

Main features:

- Possibility of extracting dust from power tools
- Switch for regulating suction power
- Input for dry vacuuming to the bag
- Input for wet vacuuming to the container
- Sophisticated filter system

Technical specifications

| | |
|-------------------------|---|
| Order Number | XT102810 |
| Voltage | 230V/50Hz |
| Input power | 1600 W |
| Vessel volume | 30 l |
| Hose length | 3 m |
| Operation mode | dry / wet |
| Power cord length | 4 m |
| Sound power level (LwA) | 80 dB |
| Product includes | Floor tube, connector, adapter, hepa and dust filter, slot nozzle, round brush, cloth bag, telescopic metal tube |
| Suction power | 19 kPa |
| Weight | 13.4 kg |

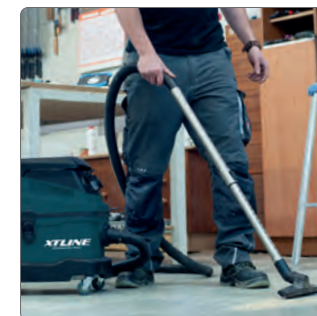



ROPE HOISTS

500/1050 W

The electric Rope Hoist is designed for vertical lifting or lowering of solid loads. Load lifting with the use of a return pulley with the weight of up to 250kg, direct load lifting with the weight of up to 125kg. Emergency switch controller; auxiliary pulley with hook

Main features:

- Auxiliary pulley with a hook
- Control unit with an emergency stop

Technical specifications

| | |
|-------------------------|-----------------|
| Order Number | XT108250 |
| Voltage | 230V/50Hz |
| Input power | 500 W |
| Max. load | 125 / 250 kg |
| Rope diameter | 3 mm |
| Lift speed | 8/4 m/min |
| Lift height | 12/6 m |
| Sound power level (LwA) | 71 dB |
| Weight | 12 kg |
| Order Number | XT108600 |
| Voltage | 230V/50Hz |
| Input power | 1050 W |
| Max. load | 300 / 600 kg |
| Rope diameter | 4.5 mm |
| Lift speed | 8/4 m/min |
| Lift height | 12/6 m |
| Sound power level (LwA) | 71 dB |
| Weight | 18 kg |



PADDLE MIXER 1600 W

The electric Paddle Mixer is used for mixing paints, and construction mixtures (grout, glue, plasters, etc.). It is equipped with a comfortable handle that ensures a firm, both-hands grip with an in-built switch and continuous speed regulation. Large switches allow easy control while wearing gloves.

Main features:

- Two-speed adjustment
- Speed regulation



Technical specifications

| | |
|----------------------------|---|
| Order Number | XT10400 |
| Voltage | 230V/50Hz |
| Input power | 1600 W |
| Speed | 180-380 / 300-650 rpm |
| Speed control positions | 2 |
| Mixing paddle length | 590 mm |
| Max. paddle diameter | 160 mm |
| Spindle thread | M14 |
| Sound pressure level (LpA) | 79 dB |
| Sound power level (LwA) | 101 dB |
| Other features | Speed regulation |
| Product includes | Paddle, a pair of carbon brushes, 2x key |
| Weight | 5.1 kg |





CONCRETE MIXERS

The Concrete Mixer is used for mixing construction mixtures, grouts, and other materials. It offers double-sided tipping and is designed for small buildings. The light construction of the tool allows easy manipulation.

Main features:

- Light construction
- Simple controls
- Cu motor winding

Technical specifications

| | |
|---------------------------|--------------------|
| Order Number | XT125H |
| Voltage | 230V/50Hz |
| Input power | 550 W |
| Speed | 2,800 rpm |
| Wheel size | 20x4.38 cm |
| Drum volume | 125 l |
| Dimensions when assembled | 1,350x710x1,200 cm |
| Drum hole diameter | 57 cm |
| Weight | 51 kg |
| Order Number | XT140H |
| Voltage | 230V/50Hz |
| Input power | 650 W |
| Speed | 2,800 rpm |
| Wheel size | 20x4.38 cm |
| Drum volume | 140 l |
| Dimensions when assembled | 1,350x710x1,200 cm |
| Drum hole diameter | 60 cm |
| Weight | 52 kg |

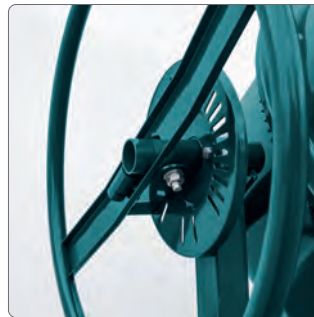



CONCRETE MIXERS

Technical specifications

| | |
|---------------------------|--------------------|
| Order Number | XT160H |
| Voltage | 230V/50Hz |
| Input power | 650 W |
| Speed | 2,800 rpm |
| Wheel size | 20x4.38 cm |
| Drum volume | 160 l |
| Dimensions when assembled | 1,370x710x1,200 cm |
| Drum hole diameter | 65 cm |
| Weight | 58 kg |
| Order Number | XT180H |
| Voltage | 230V/50Hz |
| Input power | 850 W |
| Speed | 2,800 rpm |
| Wheel size | 20x4.38 cm |
| Drum volume | 180 l |
| Dimensions when assembled | 1,400x850x1,260 cm |
| Drum hole diameter | 70 cm |
| Weight | 69.5 kg |
| Order Number | XT200H |
| Voltage | 230V/50Hz |
| Input power | 850 W |
| Speed | 2,800 rpm |
| Wheel size | 20x4.38 cm |
| Drum volume | 200 l |
| Dimensions when assembled | 1,420x850x1,260 cm |
| Drum hole diameter | 70 cm |
| Weight | 70.5 kg |

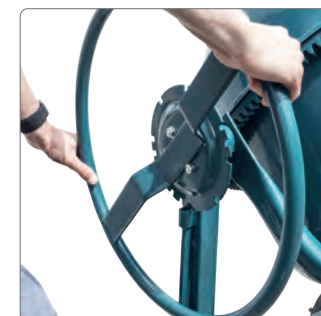



HOT GLUE GUNS

10/40 W

The electric hot glue gun is used for gluing and joining wood, cardboard, plastics, ceramics, cork, leather, etc. An irreplaceable helper in the workshop, home, decorations, arrangements and many more.

Main features:

- Small size
- Easy operation

Technical specifications

| | |
|---------------------|----------------|
| Order Number | XT10905 |
| Voltage | 230V/50Hz |
| Input power | 10 W |
| Temperature | 200 °C |
| Glue stick diameter | 7 mm |
| Preheat time | 3 - 5 min. |
| Product includes | 2x glue stick |
| Weight | 160 g |
| Order Number | XT10906 |
| Voltage | 230V/50Hz |
| Input power | 40 W |
| Temperature | 200 °C |
| Glue stick diameter | 11 mm |
| Preheat time | 3 - 5 min. |
| Product includes | 2x glue stick |
| Weight | 260 g |



HOT GLUE GUNS

100/150 W

The electric hot glue gun is used for gluing and joining wood, cardboard, plastics, ceramics, cork, leather, etc. An irreplaceable helper in the workshop, home, decorations, arrangements and many more.

Main features:

- Anti-dripping function
- Safety fuse



Technical specifications

| | |
|---------------------|----------------|
| Order Number | XT10910 |
| Voltage | 230V/50Hz |
| Input power | 100 W |
| Temperature | 200 °C |
| Glue stick diameter | 11 mm |
| Preheat time | 3 - 5 min. |
| Product includes | Tiltable stand |
| Weight | 330 g |
| Order Number | XT10916 |
| Voltage | 230V/50Hz |
| Input power | 150 W |
| Temperature | 100-200 °C |
| Glue stick diameter | 11 mm |
| Preheat time | 3 - 5 min. |
| Product includes | Tiltable stand |
| Weight | 400 g |





HOT GLUE GUN 80 W

The electric hot glue gun is used for gluing and joining wood, cardboard, plastics, ceramics, cork, leather, etc. An irreplaceable helper in the workshop, home, decorations, arrangements and many more.

Main features:

- Electronic preheating system
- Ergonomic handle
- Safety cover for glue stick

Technical specifications

| | |
|---------------------|----------------------|
| Order Number | XT10929 |
| Voltage | 230V/50Hz |
| Input power | 80 W |
| Temperature | 200 °C |
| Glue stick diameter | 10 mm |
| Product includes | 2x glue stick |
| Weight | 340 g |





CORDLESS HOT GLUE GUN

Cordless Glue Gun is designed for glue-ups and binding of wood, cardboard, plastics, ceramics, cork, leather, etc. Irreplaceable tool in workshops, households, decoration jobs, etc. Li-ion battery allows charging without decreasing the battery lifespan. The main feature is working without using the cord because the tool is equipped with a charging base that also serves as a gun holder. It starts the charging process in the moment the tool is placed in.

Main features:

- LED indication
- No power cord
- Charger stand



Technical specifications

| | |
|---------------------|---|
| Order Number | XT10918 |
| Voltage | 3.7 V |
| Input power | 15 W |
| Temperature | 200 °C |
| Glue stick diameter | 7 mm |
| Work duration | 90 min. (max.) |
| Battery charge time | 2 h |
| Preheat time | 1 min. |
| Product includes | 2x glue stick, drip pad, charging base, USB cable |
| Weight | 200 g |





TRANSFORMER SOLDERING GUN 150 W

The Transformer Soldering Gun is designed for simple soldering tasks, electrical connector soldering, model making, and burn painting.

Main features:

- Low weight
- Accessories

Technical specifications

| | |
|------------------------|---|
| Order Number | XT10930 |
| Voltage | 230V/50Hz |
| Input power | 150 W |
| Temperature | 200 °C |
| Intermittent operation | 48 s |
| Continuous operation | 12 s |
| Product includes | Rosin, soldering tips, soldering paste |
| Weight | 750 g |





HIGH PRESSURE WASHER 1800 W, SOAP APPLICATION

The High-Pressure Washer is designed for cleaning variable material surfaces (wood, stone, plastics, iron, etc.). The tool's advantage is especially cleaning of vehicles (cars, motorcycles, etc.), pavements, terraces, etc. The wheels allow very easy manipulation. All accessories can be stored in slots situated directly on the tool body.

Main features:

- Shampoo vessel
- Adjustable attachment nozzle to adjust the water spray recoil for area cleaning
- Accessory storage holder

Technical specifications

| | |
|----------------------------|---|
| Order Number | XT121701 |
| Voltage | 230V/50Hz |
| Input power | 1800 W |
| Max. fluid temperature | 35 °C |
| Max. pressure | 165 bar |
| Working pressure | 105 bar |
| Max. flow | 6 l/min |
| Product size | 410x320x573 mm |
| Sound pressure level (LpA) | 72 dB |
| Sound power level (LwA) | 83 dB |
| Product includes | 8m high-pressure hose, spray gun with adjustable nozzle, 5m power cord |
| Weight | 10.6 kg |





JET PUMP 1200 W

The electric Jet Pump with the stainless-steel head is capable of pumping water from the depth of up to 8 meters. This specific type of pump can be easily installed and run in gardens or cottages for watering purposes with the use of clean service water or rainwater. The pump is equipped with a thermal fuse.

Main features:

- Thermal and overheating fuse switch
- Stainless steel head

Technical specifications

| | |
|-------------------------|-------------------|
| Order Number | XT121200 |
| Voltage | 230V/50Hz |
| Input power | 1200 W |
| Speed | 2,850 rpm |
| Max. fluid temperature | 35 °C |
| Max. pressure | 4.6 bar |
| Max. flow | 3700 l/hod |
| Max. transport height | 46 m |
| Max. suction depth | 8 m |
| Output throat diameter | 1" |
| Power cord length | 1 m |
| Sound power level (LwA) | 85 dB |
| Weight | 8.2 kg |

SAFETY SWITCH

| | |
|--------------|-----------------|
| Order Number | XT121250 |
|--------------|-----------------|



JET PUMP WITH PRESSURE VESSEL 1200 W

The Jet Pump pressure station with automatic suction pump and pressure vessel of the volume of 19L. This tool type is very quiet and reliable, especially when increasing the water utility network pressure, irrigation of large areas, and no-contamination water supply out of wells.

Main features:

Pressure adjustment + manometer

Technical specifications

| | |
|-------------------------|--------------------|
| Order Number | XT121235 |
| Voltage | 230V/50Hz |
| Input power | 1200 W |
| Speed | 2,850 rpm |
| Max. fluid temperature | 35 °C |
| Vessel volume | 19 l |
| Max. pressure | 1.3 - 3 bar |
| Max. flow | 3700 l/hod |
| Max. transport height | 46 m |
| Max. suction depth | 8 m |
| Output throat diameter | 1" |
| Power cord length | 1 m |
| Sound power level (LwA) | 85 dB |
| Weight | 13.4 kg |

SAFETY SWITCH

| | |
|--------------|-----------------|
| Order Number | XT121250 |
|--------------|-----------------|



XT121250





SUBMERSIBLE WASTEWATER PUMP 750 W

The Submersible Pump is used for pumping contaminated water and wastewater. A great throughput of the pump allows pumping water containing solid particles and fibre impurities. The pump can also be used for pumping water out of swimming pools, brooks, ponds, etc.

Main features:

- Thermal protection against pump overheating
- Double motor insulation
- Cast iron base, metal propeller

Technical specifications

| | |
|------------------------|--------------------------------|
| Order Number | XT122075 |
| Voltage | 230V/50Hz |
| Input power | 750 W |
| Max. fluid temperature | 35 °C |
| Max. flow | 19980 l/hod = 333 l/min |
| Max. throughput | 25 mm |
| Max. discharge | 10 m |
| Max. immersion depth | 5 m |
| Output throat diameter | 2" |
| Power cord length | 6 m |
| Weight | 16.1 kg |

SUBMERSIBLE WASTEWATER PUMP 1100 W

The Submersible Pump is used for pumping contaminated water and wastewater. A great throughput of the pump allows pumping water containing solid particles and fibre impurities. The pump can also be used for pumping water out of swimming pools, brooks, ponds, etc.

Main features:

- Thermal protection against pump overheating
- Double motor insulation
- Stainless steel base, metal propeller

Technical specifications

| | |
|------------------------|--------------------------------|
| Order Number | XT122110 |
| Voltage | 230V/50Hz |
| Input power | 1100 W |
| Max. fluid temperature | 35 °C |
| Max. flow | 23100 l/hod = 385 l/min |
| Max. throughput | 25 mm |
| Max. discharge | 11,5 m |
| Max. immersion depth | 5 m |
| Output throat diameter | 2" |
| Power cord length | 8 m |
| Weight | 16.7 kg |





SUBMERSIBLE PUMP 1000 W

The electric Submersible Pressure Pump with a stainless-steel body and float switch is suitable for pumping clean water. It can be used for operations requiring pumping water out of more highly situated places, or water sumps.

Main features:

Suction capability from minimum depth

Technical specifications

| | |
|------------------------|------------------------------|
| Order Number | XT120100 |
| Voltage | 230V/50Hz |
| Input power | 1000 W |
| Max. fluid temperature | 35 °C |
| Max. pressure | 4 bar |
| Max. flow | 5500 l/hod = 92 l/min |
| Max. throughput | 1 mm |
| Max. discharge | 40 m |
| Max. immersion depth | 7 m |
| Output throat diameter | 1" |
| Power cord length | 10 m |
| Base diameter | 160 mm |
| Weight | 8.5 kg |

SUBMERSIBLE BARREL PUMP 400 W

The electric Submersible Pump for pumping rainwater. It offers a plastic construction and float switch that ensures an automatic turn-off according to the water level height.

Main features:

- Adjustable hinge with lock
- Base with a suction grid

Technical specifications

| | |
|------------------------|-------------------|
| Order Number | XT11250 |
| Voltage | 230V/50Hz |
| Input power | 400 W |
| Max. fluid temperature | 35 °C |
| Max. pressure | 1,1 bar |
| Max. flow | 4000 l/hod |
| Max. throughput | 0.5 mm |
| Max. discharge | 7 m |
| Max. immersion depth | 11 m |
| Output throat diameter | 3/4" |
| Power cord length | 10 m |
| Base diameter | 190 mm |
| Weight | 3.7 kg |

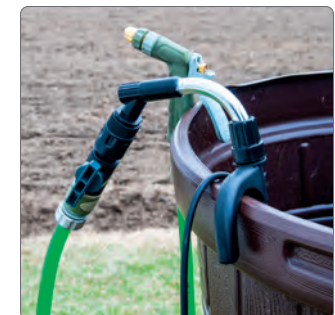



SUBMERSIBLE PUMPS

400/750 W

The electric Submersible Sludge Pump is designed for pumping wells, swimming pools, rainwater sumps, water treatment stations, flooded basements, etc.

Main features:

Suction capability from minimum depth

Technical specifications

| | |
|------------------------|------------------------|
| Order Number | XT11400 |
| Voltage | 230V/50Hz |
| Input power | 400 W |
| Max. fluid temperature | 35 °C |
| Max. flow | 8000 l/hod = 133 l/min |
| Max. throughput | 35 mm |
| Max. discharge | 7 m |
| Max. immersion depth | 5 m |
| Output throat diameter | 1", 5/4", 6/4" |
| Power cord length | 10 m |
| Weight | 4.9 kg |

| | |
|------------------------|-------------------------|
| Order Number | XT11750 |
| Voltage | 230V/50Hz |
| Input power | 750 W |
| Max. fluid temperature | 35 °C |
| Max. flow | 13500 l/hod = 225 l/min |
| Max. throughput | 35 mm |
| Max. discharge | 8 m |
| Max. immersion depth | 7 m |
| Output throat diameter | 1", 5/4", 6/4" |
| Power cord length | 10 m |
| Weight | 6.3 kg |



SUBMERSIBLE PUMP 1100 W

The electric Submersible Sludge Pump is designed for pumping wells, swimming pools, rainwater sumps, water treatment stations, flooded basements, etc. The propeller located in the suction part grinds the fibre materials, such as leaves, paper, etc. The machine is equipped with a switch that ensures a better safety level that prevents the machine from starting when it is out of water.

Main features:

- Durable stainless-steel body
- Dry start-up protection switch



Technical specifications

| | |
|------------------------|--------------------------------|
| Order Number | XT121100 |
| Voltage | 230V/50Hz |
| Input power | 1100 W |
| Max. fluid temperature | 35 °C |
| Max. flow | 18500 l/hod = 308 l/min |
| Max. throughput | 20 mm |
| Max. discharge | 8 m |
| Max. immersion depth | 7 m |
| Output throat diameter | 1", 5/4", 6/4" |
| Power cord length | 8 m |
| Weight | 7.8 kg |

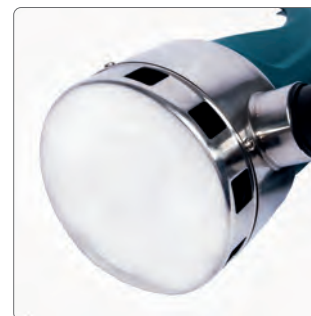

LIST OF ORDER NUMBERS

| Order number | page | Order number | page | Order number | page | Order number | page | Order number | page |
|--------------|------|---------------|------|--------------|------|--------------|------|--------------|------|
| XT102600 | 4 | XT102875 | 34 | XT106010 | 52 | XT106322 | 78 | XT2011 | 108 |
| XT102630 | 5 | XT102875-2B2 | 34 | XT106040 | 53 | XT107060 | 79 | XT2008 | 109 |
| XT102106 | 6 | XT102895 | 35 | XT106050 | 54 | XT107100 | 80 | XT102819 | 110 |
| XT102840 | 7 | XT102895-2B2 | 35 | XT106061 | 55 | XT107125 | 81 | XT102810 | 111 |
| XT102699 | 8 | XT102910 | 36 | XT106057 | 56 | XT107150 | 81 | XT108250 | 112 |
| XT102698 | 8 | XT102910-1B2 | 36 | XT106335 | 57 | XT107175 | 82 | XT108600 | 112 |
| XT102700 | 9 | XT102880 | 37 | XT105115 | 58 | XT107200 | 83 | XT10400 | 113 |
| XT102770E | 10 | XT102880-2B2 | 37 | XT105125 | 59 | XT108802 | 84 | XT125H | 114 |
| XT102800 | 11 | XT102890 | 38 | XT105150 | 60 | XT108803 | 85 | XT140H | 114 |
| XT102860E | 12 | XT102890-2B4 | 38 | XT105240 | 61 | XT108808 | 86 | XT160H | 115 |
| XT102865E | 13 | XT102935 | 39 | XT105130 | 62 | XT106395 | 88 | XT180H | 115 |
| XT102710 | 14 | XT102935-2B4 | 39 | XT105305 | 64 | XT106400 | 89 | XT200H | 115 |
| XT102760E | 15 | XT102940 | 40 | XT105337 | 64 | XT106160 | 90 | XT10905 | 116 |
| XT102830 | 16 | XT102940-1B2 | 40 | XT105306 | 65 | YT106187 | 91 | XT10906 | 116 |
| XT102720 | 18 | XT102785 | 41 | XT105345 | 65 | XT106190 | 92 | XT10910 | 117 |
| XT102835 | 19 | XT102790 | 41 | XT105307 | 66 | XT106372 | 93 | XT10916 | 117 |
| XT102725 | 20 | XT102792 | 42 | XT105325 | 66 | XT106390 | 94 | XT10929 | 118 |
| XT102740 | 21 | XT102782E | 43 | XT105312 | 67 | XT106360 | 95 | XT10918 | 119 |
| XT102755 | 22 | XT102784E | 43 | XT105140 | 67 | XT106365 | 96 | XT10930 | 120 |
| XT102750 | 23 | XT102786E | 43 | XT105315 | 68 | XT106368 | 97 | XT121701 | 121 |
| XT102745 | 24 | XT102787E | 43 | XT105320 | 68 | XT106210 | 98 | XT121200 | 122 |
| XT102845 | 25 | XT102730-1B2B | 44 | XT105319 | 69 | XT106255 | 99 | XT121235 | 123 |
| XT102735 | 26 | XT102735-1B2B | 44 | XT105342 | 69 | XT106260 | 100 | XT122075 | 124 |
| XT102730 | 28 | XT102750-1B5B | 44 | XT106200 | 70 | XT106305 | 101 | XT122110 | 125 |
| XT102850 | 29 | XT102835-1B5B | 44 | XT105340 | 71 | XT101001 | 102 | XT120100 | 126 |
| XT102775 | 30 | XT102840-1B5B | 44 | XT106310 | 72 | XT103001 | 103 | XT11250 | 127 |
| XT102765 | 31 | XT102845-1B5B | 44 | XT105350 | 73 | XT103160 | 104 | XT11400 | 128 |
| XT102768 | 31 | XT106120 | 48 | XT105300 | 74 | XT106220 | 105 | XT11750 | 128 |
| XT102795 | 32 | XT106130 | 49 | XT106235 | 75 | XT106230 | 105 | XT121100 | 129 |
| XT102870 | 33 | XT106150 | 50 | XT106245 | 76 | XT2002 | 106 | | |
| XT102870-2B4 | 33 | XT106005 | 51 | XT106382 | 77 | XT2004 | 107 | | |

A series of horizontal dotted lines for writing notes, spanning the width of the page.

Born for outstanding projects.

www.xtline.cz

